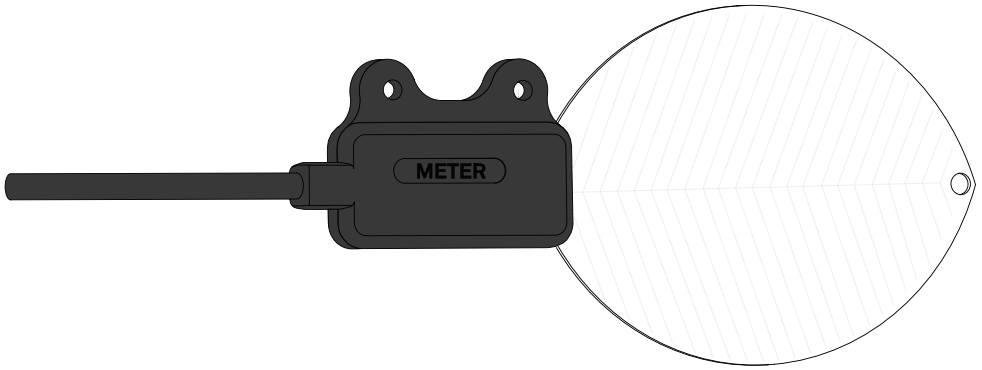

TABLE OF CONTENTS

1. Introduction	1
2. Operation	2
2.1 Installation	2
2.2 Connecting	3
2.2.1 Connect to METER Data Logger	4
2.2.2 Connect to a Non-METER Data Logger	4
2.3 Interpreting Data	6
2.3.1 Understanding Data from METER Data Loggers	6
2.3.2 Understanding Data from Other Data Loggers	8
3. System	9
3.1 Specifications	9
3.2 Components	10
3.3 Theory	11
4. Service	12
4.1 Calibration	12
4.2 Cleaning and Maintenance	12
4.3 Troubleshooting	12
4.4 Customer Support	13
4.5 Terms and Conditions	14
Index	15



1. INTRODUCTION

Thank you for choosing the PHYTOS 31 Leaf Wetness Sensor from METER Group.

The PHYTOS 31 measures leaf surface wetness by measuring the dielectric constant of the sensor's upper surface ([Section 3.3](#)). It has a very low power requirement, which allows for many measurements over a long period of time with minimal battery usage. This sensor also has very high resolution, which detects very small amounts of water (or ice). The PHYTOS 31 does not need to be painted before use, eliminating the need for individual sensor calibration.

Prior to use, verify the PHYTOS 31 arrived in good condition.

2. OPERATION

Please read all instructions before operating the PHYTOS 31 to ensure it performs to its full potential.

PRECAUTIONS

METER instruments are built to the highest standards, but misuse, improper protection, or improper installation may damage the sensor and possibly void the manufacturer's warranty. Before integrating PHYTOS 31 into a system, make sure to follow the recommended installation instructions and have the proper protections in place to safeguard sensors from damage.

2.1 INSTALLATION

The PHYTOS 31 is designed to be deployed either in the canopy or on weather station masts. Follow the steps in [Table 1](#) to set up the PHYTOS 31 and start collecting data.

Table 1 Installation

Tools Needed	<p>Mounting post or other mounting apparatus</p> <p>Zip ties or 4-40 bolts</p>
Preparation	<p>Apply Ultraviolet (UV) Protectant (Section 4.2).</p> <p>Install Sensor to Mounting Post</p> <p>Install the mounting post either in or above the canopy, as needed (Figure 1).</p> <p>Hold the PHYTOS 31 sensor with the electrode traces facing up.</p> <p>Thread zip ties or 4-40 bolts through the two mounting holes on the sensor body and attach them to the mounting apparatus at the appropriate height.</p> <p>NOTE: Wetness duration will be affected by the mounting angle. Ensure the PHYTOS 31 is mounted at the appropriate angle for the desired measurement. A 45-degree angle is typical when mimicking plant canopy wetness.</p>
Mounting	 <p>Figure 1 PHYTOS 31 installation</p>

Table 1 Installation (continued)

Connecting	Select location for data logger and cable
	Connect to Logger
	Plug the sensor into the logger.
	In ZENTRA Utility, select PHYTOS 31 for the appropriate port.
	Use the data logger to make sure the sensor is reading properly.
	Verify that these readings are within expected ranges.
Secure and Protect Cables	
Install cables in conduit or plastic cladding when near the ground to avoid rodent damage.	
NOTE: Improperly protected cables can lead to severed cables or disconnected sensors. Cabling issues can be caused by many factors such as rodent damage, driving over sensor cables, tripping over cables, not leaving enough cable slack during installation, or poor sensor wiring connections.	
Relieve strain on the connections and prevent loose cabling from being inadvertently snagged by gathering and securing the cables between the PHYTOS 31 and the data logger to the mounting mast in one or more places.	
Tie excess vertical cable to the data logger mast to ensure cable weight does not cause sensor to unplug.	

2.2 CONNECTING

The PHYTOS 31 works seamlessly with METER data loggers. The sensor can also be used with other data loggers, such as those from Campbell Scientific, Inc.

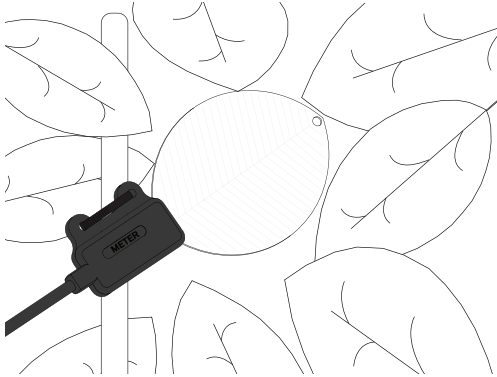
The PHYTOS 31 sensor requires excitation voltages in the range of 2.5 to 5.0 VDC and outputs a single-ended DC voltage that is proportional to the amount of water on the sensor surface.

PHYTOS 31 produces an output voltage that depends on the dielectric constant of the medium surrounding the sensor and ranges between 10% to 50% of the excitation voltage. Any data logger that can produce a 2.5- to 5.0-V excitation with approximately 10-ms duration and read a voltage-level signal with 12-bit or better resolution should be compatible with the PHYTOS 31. The current requirement at 2.5 V is around 2 mA and the requirement at 5 V is 7 to 8 mA.

NOTE: The PHYTOS 31 is intended only for use with data loggers and readout devices that can provide short excitation pulses, leaving the sensor turned off most of the time. Continuous excitation not only wastes battery power, but may, under certain circumstances, cause the sensor to exceed government-specified limits on electromagnetic emissions.

PHYTOS 31 sensors come with a 3.5-mm stereo plug connector (Figure 2) to facilitate easy connection with METER loggers. PHYTOS 31 sensors may be ordered with stripped and tinned wires to facilitate connecting to some third-party loggers (Section 2.2.2).

OPERATION



Figure 2 Stereo plug connector

The PHYTOS 31 comes standard with a 5-m cable. It may be purchased with custom cable lengths for an additional fee (on a per-meter basis). Cable length can be increased up to 40 m without significant signal attenuation.

2.2.1 CONNECT TO METER DATA LOGGER

The PHYTOS 31 works most efficiently with METER ZENTRA, EM60, or Em50 series data loggers. Check the [METER download webpage](#) for the most recent data logger firmware. Logger configuration may be done using either ZENTRA Utility (desktop and mobile application) or ZENTRA Cloud (web-based application for cell-enabled data loggers).

1. Plug the stereo plug connector into one of the sensor ports on the logger.
2. Use the appropriate software application to configure the chosen logger port for the PHYTOS 31.
3. Set the measurement interval.

PHYTOS 31 data can be downloaded from these loggers using either ZENTRA Utility or ZENTRA Cloud. Refer to the logger user manual for more information about these programs.

2.2.2 CONNECT TO A NON-METER DATA LOGGER

The PHYTOS 31 can be used with non-METER (third-party) data loggers. Refer to the third-party logger manual for details on single-ended voltage measurements, power supply, and ground ports. Non-METER data loggers may require programming to read the PHYTOS 31. METER has [a sample program](#) for interfacing with Campbell Scientific, Inc. data loggers.

The PHYTOS 31 sensors can be ordered with stripped and tinned (pigtail) wires for use with screw terminals. Refer to the third-party logger manual for details on wiring.

Connect the PHYTOS 31 wires to the data logger as illustrated in [Figure 3](#) and [Figure 4](#), with the power supply wire (brown) connected to the excitation, the analog out wire (orange) to a single-ended voltage input, and the bare ground wire to ground.

PHYTOS 31

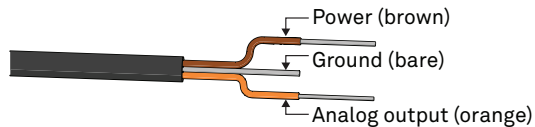

Figure 3 Pigtail wiring

NOTE: LWS (predecessor to PHYTOS 31) may have the older Decagon wiring scheme where the power supply is white, the analog is red, and the bare wire is ground.

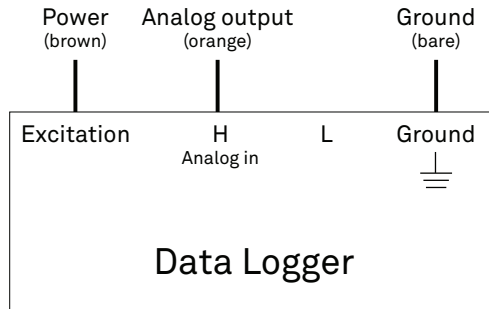

Figure 4 Wiring diagram

NOTE: The acceptable range of excitation voltages is from 2.5 to 5.0 VDC.

If the PHYTOS 31 cable has a standard stereo plug connector and needs to be connected to a non-METER data logger, use one of the following two options.

Option 1

1. Clip off the stereo plug connector on the sensor cable.
2. Strip and tin the wires.
3. Wire it directly into the data logger.

This option has the advantage of creating a direct connection and minimizes the chance of the sensor becoming unplugged. However, it then cannot be easily used in the future with a METER readout unit or data logger.

Option 2

Obtain an adapter cable from METER.

The adapter cable has a connector for the stereo plug connector on one end and three wires (or pigtail adapter) for connection to a data logger on the other end. The stripped and tinned adapter cable wires have the same termination as in [Figure 4](#): the brown wire is excitation, the orange is output, and the bare wire is ground.

NOTE: Secure the stereo plug connector to the pigtail adapter connections using adhesive-line heat shrink to ensure the sensor does not become disconnected during use.

2.3 INTERPRETING DATA

Most leaf wetness applications (for disease forecasting, etc.) only require knowledge of any water on the surface of the leaf, not knowledge of the amount of water. To make this determination, a sensor output threshold corresponding to the minimum wet state must be identified.

A dry PHYTOS 31 outputs approximately 435 raw counts when read with METER data loggers. When the sensor is totally wet, as in a heavy rain, the signal can range up to around 1,100 counts. Varying amounts of water on the surface of the sensor cause a sensor output proportional to the amount of water on the sensor's surface. Ice has a much lower dielectric constant than that of liquid water, so the sensor output from frost is much lower than that from a similar amount of rain or dew (Figure 5).

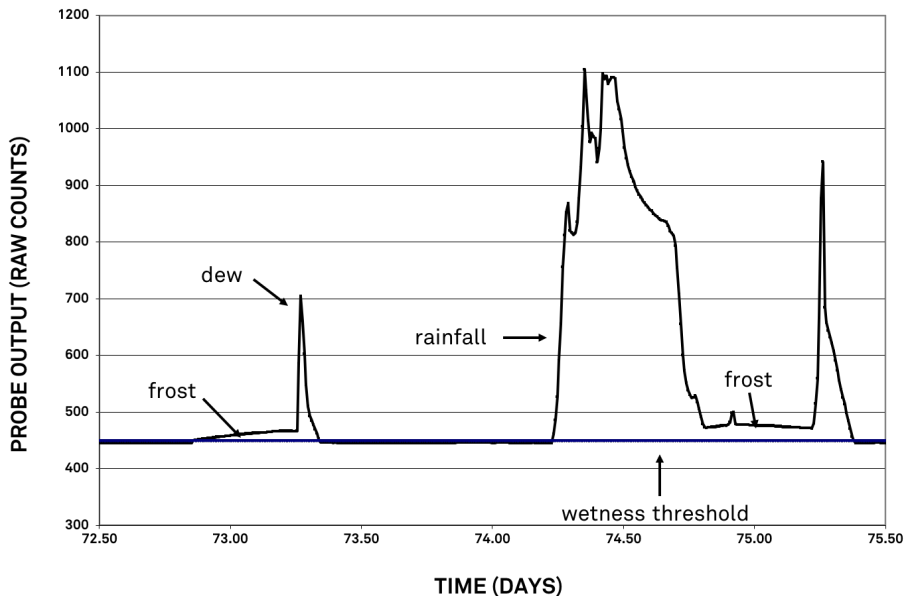

Figure 5 Example raw PHYTOS 31 output

2.3.1 UNDERSTANDING DATA FROM METER DATA LOGGERS

With METER data loggers, users have two options for interpreting data: using number of minutes wet (processed data) or raw probe output (raw data). The sensors are factory calibrated to read 435 raw counts when dry. When configuring a METER logger port to read the PHYTOS 31, the logger reads the sensor every minute and compares the data to two predefined wetness thresholds of 450 and 460 raw counts to determine the number of minutes wet during a measurement interval.

Three columns of data are output in a Microsoft® Excel® spreadsheet for each PHYTOS 31 port.

- Column 1: The number of minutes that the PHYTOS 31 output was over 450 raw counts in the preceding wake interval. For example, if a 30-min wake interval is selected, then the number can range from 0 (the sensor was never wet during the 30-min period) to 30 (the sensor was always wet during that 30-min period). The sum of the numbers in this column yields the cumulative wetness duration (in minutes) during the time period of interest.
- Column 2: The number of minutes that the PHYTOS 31 output was over 460 raw counts in the preceding wake interval. The data in this column follow the same format as those in column 1, only with a slightly higher wetness threshold. Field tests for the PHYTOS 31 indicate extreme dust buildup or bird droppings can cause the dry output of the sensor to climb above the 450 raw count threshold. If this occurs, values in column 1 will be higher than values in column two. The data in column 2 can be used until the sensor can be cleaned.
- Column 3: The final reading in raw counts of the PHYTOS 31 during the wake interval. For example, if a 30-min wake interval has been chosen, the number in column 3 is the output in raw counts from the PHYTOS 31 during the last minute of that 30-min period. This data column can be used in the event of an extremely dirty PHYTOS 31, which may force the dry output higher than 460 raw counts. In this case, the user can identify a new wetness threshold from the time series data and calculate wetness duration from the new threshold until the sensor can be cleaned ([Section 2.3.2](#)). The data in this column only gives a wetness reading every wake interval (typically 30 min or more), instead of the 1-min wetness resolution available in column 1 and 2. This column can also be used for understanding the phase of the water, as shown in [Figure 5](#), as well as the amount of water (as discussed in [Predicting the amount of water on the surface of the PHYTOS 31 dielectric leaf wetness sensor](#)).

Em50 data loggers provide an unprocessed Excel file format with three columns of data for each PHYTOS 31 port.

- Column 1: The cumulative number of minutes that the PHYTOS 31 output has been over 450 raw counts since the Em50 data were last erased or the accumulator has rolled over. The accumulator has a maximum of 2,048 min (1.42 days) of wetness. If the cumulative wetness duration exceeds this window (which likely happens often), then the accumulator resets to 0 and begins accumulating again.
- Column 2: The cumulative number of minutes that the PHYTOS 31 output has been over 460 raw counts since the Em50 data were last erased or the accumulator has rolled over. The accumulator rolls over to 0 after 2,048 min of wetness.
- Column 3: The final reading in raw counts of the PHYTOS 31 during the wake interval.

2.3.2 UNDERSTANDING DATA FROM OTHER DATA LOGGERS

With non-METER data loggers, the user needs to establish a wetness threshold for their system. The dry output of the PHYTOS 31 varies with excitation voltage. The acceptable excitation voltage range is 2.5 to 5.0 V. See [Table 2](#) for varying voltage for dry output and wetness threshold.

Table 2 Non-METER data logger voltage

Excitation voltage	Dry output	Wetness threshold
VDC	mV	mV
2.5	260	274
3	320	330
5	530	547

The PHYTOS 31 dry output is easily determined from time series data such as those presented in [Figure 5](#). A wetness threshold should be chosen that is slightly above the dry output, and subsequent readings should be compared to the dry output to determine surface wetness. When using a non-METER data logger, it is important to collect data frequently enough to capture changes in the surface wetness. A sampling frequency of 15 min or less is often necessary to accurately capture leaf wetness duration.

3. SYSTEM

This section describes the specifications, components, and theory of the PHYTOS 31 Leaf Wetness Sensor.

3.1 SPECIFICATIONS

PHYSICAL SPECIFICATIONS

Dimensions

Length	12.0 cm (4.7 in)
Width	5.8 cm (2.3 in)
Height	0.8 cm (0.3 in)

Operating Temperature Range

Minimum	-40 °C
Typical	NA
Maximum	+60 °C

NOTE: Sensors may be used at higher temperatures under certain conditions; contact [Customer Support](#) for assistance.

Cable Length

- 5 m (standard)
- 40 m (maximum custom cable length)

NOTE: Contact [Customer Support](#) if a nonstandard cable length is needed.

Cable Diameter

0.165 ±.004 (4.20 ± .10 mm) with min. jacket of .030 (.76 mm)

Connector Types

3.5-mm stereo plug connector or stripped and tinned wires

Stereo Plug Connector Diameter

3.50 mm

Conductor Gauge

22 AWG/24 AWG drain wire

ELECTRICAL AND TIMING CHARACTERISTICS

Supply Voltage

Minimum	2.5 VDC
Typical	NA
Maximum	5.0 VDC

Settling Time

10 ms

Output

300–1,250 mV (depends on excitation voltage)

Data Logger Compatibility

Data acquisition systems capable of switched 2.5–5.0 VDC excitation and single-ended voltage measurement at greater than or equal to 12-bit resolution.

COMPLIANCE

EM ISO/IEC 17050:2010 (CE Mark)

EN 55011:2016/A1:2017 (GROUP 1, CLASS A-RCM mark)



3.2 COMPONENTS

The PHYTOS 31 measures leaf surface wetness by measuring the dielectric constant of the sensor's upper surface. It has a very low power requirement, which allows for many measurements over a long period of time (such as a growing season) with minimal battery usage. This sensor also has very high resolution, which allows for detection of very small amounts of water (or ice) on the sensor surface. Water on the sensor surface does not need to bridge electrical traces to be detected, as is common with resistance-based surface wetness sensors. This means that the PHYTOS 31 does not need to be painted before use, which eliminates the need for individual sensor calibration.

PHYTOS 31

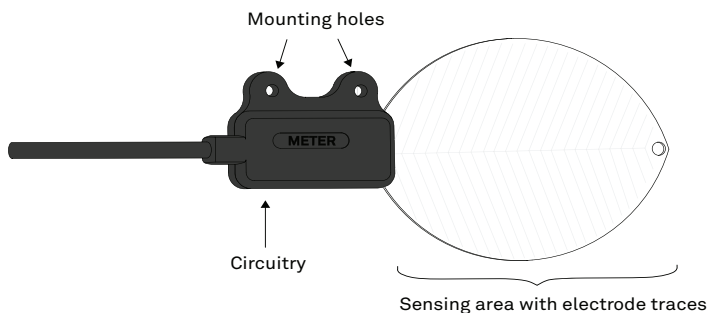

Figure 6 PHYTOS 31 sensor

3.3 THEORY

The PHYTOS 31 measures the dielectric constant of an approximately 1-cm zone from the upper surface of the sensor. The dielectric constant of water (80) and ice (5) are much higher than that of air (1), so the measured dielectric constant strongly depends on the presence of moisture or frost on the sensor surfaces. The sensor outputs a millivolt signal proportional to the dielectric of the measurement zone, and therefore proportional to the amount of water or ice on the sensor surface.

The sensor has been specially designed to closely approximate the thermodynamic properties of a leaf. If the specific heat of a leaf is estimated at 3,750 J/kgK, the density is estimated to be 0.95 g/cm³, and the thickness of a typical leaf is 0.4 mm, then the heat capacity of the leaf is 1,425 J/m²K. This is closely approximated by the thin (0.65-mm) fiberglass construction of the PHYTOS 31, which has a heat capacity of 1,480 J/m²K. By mimicking the thermodynamic properties of a real leaf, the PHYTOS 31 more closely matches the wetness state of the canopy.

The sensor has also been engineered to closely match the radiative properties of real leaves. Healthy leaves generally absorb solar radiation effectively in much of the visible portion of the spectrum, but selectively reject much of the energy in the near-infrared portion of the spectrum. The surface coating of the PHYTOS 31 absorbs well in the near-infrared region, but the white color reflects most of the visible radiation. Spectroradiometer measurements indicate that the overall radiation balance of the sensor closely matches that of a healthy leaf. During normal use, prolonged exposure to sunlight can cause some yellowing of the PHYTOS 31. This is expected and does not affect the sensor function.

The surface coating of the PHYTOS 31 is hydrophobic, similar to a leaf with a hydrophobic cuticle. The sensor should match the wetness state of these types of leaves well, but may not match the wetness duration of leaves with plentiful leaf hairs or less waxy cuticles. It is impossible for any sensor to accurately mimic the properties of all leaves.

The PHYTOS 31 is engineered to be repeatable among units, so that relationships can be determined between the wetness state of the sensor and the wetness state of various agricultural or natural plant canopies.

4. SERVICE

This section describes the calibration and maintenance of the PHYTOS 31. Troubleshooting solutions and customer service information are also provided.

4.1 CALIBRATION

Painting and individual sensor calibration is not necessary with the PHYTOS 31 ([Section 3.2–Section 3.3](#)).

4.2 CLEANING AND MAINTENANCE

Over time, the accumulation of dust and bird droppings can cause the dry output to rise. The sensor should be cleaned periodically using a cloth moistened with only water. The sensor should also be cleaned when elevated dry output is detected.

Adding UV protectant will extend the service life of the PHYTOS 31 and is highly recommended. The PHYTOS 31 leaf wetness sensor is designed to withstand typical outdoor radiation and precipitation loads for greater than 2 years. However, application of UV protectant is strongly recommended and is essential if using the PHYTOS 31 in areas with unusually high radiation loads. The PHYTOS 31 comes pretreated with UV protectant, but METER recommends reapplying Gear Aid UV Protectant every 45 days. Gear Aid is the only tested and approved UV blocking system for the PHYTOS 31.

To apply Gear Aid UV Protectant:

1. Wipe sensor clean using water and a clean, soft cloth.
2. Spray soft cloth with Gear Aid spray.
3. Rub both sides of the sensor surface with wet cloth to apply protectant.

PHYTOS 31 is ready for use. Gear Aid will dry quickly in open air setting.

Contact [Customer Support](#) for more information.

4.3 TROUBLESHOOTING

[Table 3](#) lists common problems and their solutions. If the problem is not listed or these solutions do not solve the issue, contact Customer Support.

Table 3 Troubleshooting the PHYTOS 31

Problem	Possible Solutions
PHYTOS 31 not responding	Check power to the sensor.
	Check sensor cable and stereo plug connector integrity.
Sensor dry reading is too high	Check data logger wiring to ensure brown is power supply, orange is analog out, and bare is ground.
	NOTE: Some LWS sensors may have the older Decagon wiring scheme where the power supply is white, the analog out is red, and the bare wire is ground.
Cable or stereo plug connector failure	Clean the sensor.
	Apply UV protectant.
Cable or stereo plug connector failure	If the stereo plug connector is damaged or needs to be replaced, contact Customer Support for a replacement connector and splice kit.
	If a cable is damaged, follow these instructions to repair the cable.

4.4 CUSTOMER SUPPORT

NORTH AMERICA

Customer service representatives are available for questions, problems, or feedback Monday through Friday, 7:00 am to 5:00 pm Pacific time.

Email: support.environment@metergroup.com
sales.environment@metergroup.com

Phone: +1.509.332.5600

Fax: +1.509.332.5158

Website: metergroup.com

EUROPE

Customer service representatives are available for questions, problems, or feedback Monday through Friday, 8:00 to 17:00 Central European time.

Email: support.europe@metergroup.com
sales.europe@metergroup.com

Phone: +49 89 12 66 52 0

Fax: +49 89 12 66 52 20

Website: metergroup.com

SERVICE

If contacting METER by email, please include the following information:

Name	Email address
Address	Instrument serial number
Phone	Description of the problem

NOTE: For products purchased through a distributor, please contact the distributor directly for assistance.

4.5 TERMS AND CONDITIONS

By using METER instruments and documentation, you agree to abide by the METER Group Terms and Conditions. Please refer to metergroup.com/terms-conditions for details.

INDEX

C

- cable length 9
- calibration 12
- cleaning 12
- compliance 10
- components 10–11
 - connector types 9
- customer support
 - North America 13

D

- data 6–8
- data logger
 - connecting 3–5
 - METER logger 4, 6–7
 - non-METER logger 4–5, 8
 - requirements 10

E

- email address 13

F

- fax number 13

I

- installation 2–3
 - location 2
 - preparation 2
 - tools required 2

M

- maintenance 12, 13

O

- operation 11

P

- phone number 13

S

- specifications 9–12
 - electrical and timing 10–11
 - physical 9

T

- terms and conditions 14
- theory 11
- thermal properties 11
- troubleshooting 12–13

U

- UV protectant 2, 12, 13