



METER

TEROS 22



TABLE OF CONTENTS

1. Introduction	1
2. Operation	2
2.1 Installation	2
2.1.1 Preparation	2
2.1.2 Installation Angle	3
2.1.3 Installation Depth	3
2.1.4 Test Connection	6
2.1.5 Installation Methods	6
2.2 Connecting	9
2.2.1 Adding a Custom Shaft Extension	9
2.2.2 Connect to METER Logger	10
2.2.3 Connect to Non-METER Logger	10
2.3 Communication	11
3. System	13
3.1 Specifications	13
3.2 Components	16
3.3 Theory	17
3.3.1 Water Potential Measurement	17
3.3.2 Measurement Range	18
3.3.3 Measurement Accuracy	18
3.3.4 Temperature Measurement	19

3.4 Considerations.....	19
3.4.1 Measuring in Frozen Soils	19
3.4.2 Measuring in High Salinity	20
3.4.3 Temperature Sensitivity.....	20
4. Service.....	21
4.1 Calibration	21
4.2 Maintenance.....	21
4.3 Troubleshooting.....	22
4.4 Customer Support.....	22
4.5 Terms and Conditions	23
References	24
Index	25



1. INTRODUCTION

Thank you for purchasing the TEROS 22 Soil Water Potential Sensor from METER Group. Prior to use, verify the TEROS 22 arrived in good condition.

The TEROS 22 is designed to be a maintenance-free matric potential sensor for long-term, continuous field measurements. The TEROS 22 measures the dielectric permittivity of a solid matrix to determine the water content of the solid matrix. The relationship between water content and matric potential, known as the soil moisture characteristic curve, is used to calculate the soil matric potential of the solid matrix. This measurement approach along with the calibration process used in production allows for accurate measurements of water potential.

2. OPERATION

Please read all instructions before operating the TEROS 22 to ensure it performs to its full potential.

PRECAUTIONS

METER sensors are built to the highest standards, but misuse, improper protection, or improper installation may damage the sensor and possibly void the manufacturer's warranty. Before integrating TEROS 22 into a system, make sure to follow the recommended installation instructions and have the proper protections in place to safeguard sensors from damage.

2.1 INSTALLATION

Follow the steps for installation provided in this section ([Section 2.1.1](#) through [Section 2.1.5](#)) before collecting data. It is critical that the TEROS 22 sensor has good hydraulic contact with the soil to make accurate measurements.

TOOLS NEEDED

The tools required to install the TEROS 22 include:

- Masonry drill bit (5/8 in [16 mm]—the drill bit should be long enough for the desired installation depth)
- Electric drill
- Level with an angle finder
- Ruler
- Water (for packing soil or making slurry)
- Shovel (if digging a trench)
- Plastic (large piece) or tarp (if digging a trench)

2.1.1 PREPARATION

Consider the surroundings and select a secure mounting location for the data logger and cables. The data logger installation location should be based on relative details such as a representative field position for sensor installation, vegetation cover throughout the season, distance from power lines, minimal livestock interference, etc. Refer to the data logger manual for installation information.

The following sections cover installation configuration for typical depths as well as deeper than typical depth installations.

2.1.2 INSTALLATION ANGLE

The TEROS 22 should be installed at an angle (α) of 0° to 80° from horizontal (Figure 1). An angled installation position does not disturb typical water flow and reduces the chances of preferential water flow along the shaft.

The exact installation angle will depend on the individual measuring task, site, and depth.

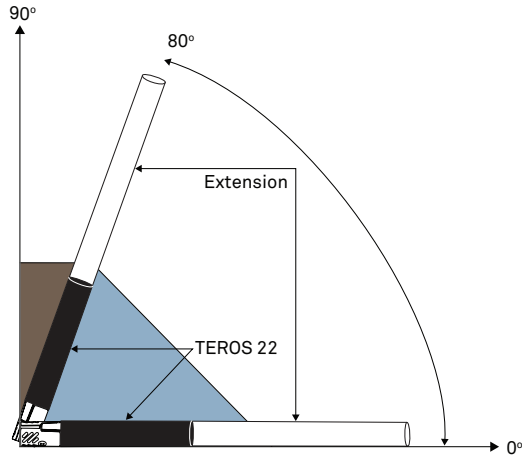

Figure 1 Recommended installation angle

2.1.3 INSTALLATION DEPTH

Figure 2 shows the reference points for water potential measurement. Water potential is referenced to the middle of the ceramic cup, so the measuring point is 0.7 cm from the ceramic tip.

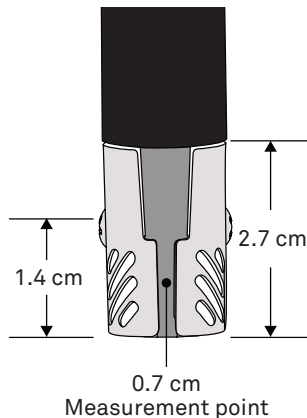

Figure 2 Position of reference points for water potential measurement

Because the TEROS 22 should be installed at an angle from horizontal (α), installation depth is not equal to drilling depth (Figure 3). To calculate the correct drilling depth, use Equation 1 or Table 1.

$$\text{drilling depth} = \frac{\text{installation depth}}{\sin\alpha}$$

Equation 1

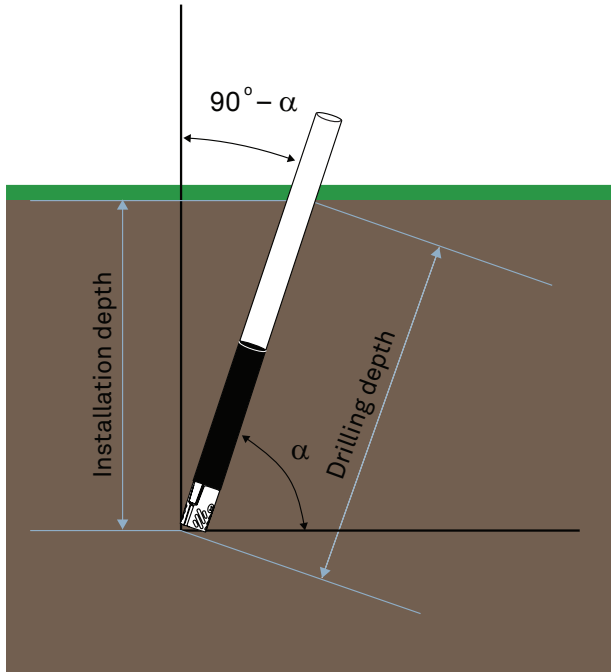

Figure 3 Drilling depth depending on installation angle

OPERATION

Table 1 Drilling depth in centimeters for installation depths and angles

	Installation Angle														
	80°	75°	70°	65°	60°	55°	50°	45°	40°	35°	30°	25°	20°	15°	10°
10	10	10	11	11	12	12	13	14	16	17	20	24	29	39	58
20	20	21	21	22	23	24	26	28	31	35	40	47	58	77	115
30	30	31	32	33	35	37	39	42	47	52	60	71	88	116	173
40	41	41	43	44	46	49	52	57	62	70	80	95	117	155	
50	51	52	53	55	58	61	65	71	78	87	100	118	146	193	
60	61	62	64	66	69	73	78	85	93	105	120	142	175		
70	71	72	74	77	81	85	91	99	109	122	140	166	205		
80	81	83	85	88	92	98	104	113	124	139	160	189			
90	91	93	96	99	104	110	117	127	140	157	180	213			
100	102	104	106	110	115	122	131	141	156	174	200				
110	112	114	117	121	127	134	144	156	171	192	220				
120	122	124	128	132	139	146	157	170	187	209					
130	132	135	138	143	150	159	170	184	202						
140	142	145	149	154	162	171	183	198	218						
150	152	155	160	166	173	183	196	212							
160	162	166	170	177	185	195	209								
170	173	176	181	188	196	208									
180	183	186	192	199	208	220									
190	193	197	202	210	219										
200	203	207	213	221											

2.1.4 TEST CONNECTION

Test the sensor function by plugging it into the data logger and make sure the sensor and data logger work properly. See [Section 2.2](#) for connecting instructions.

2.1.5 INSTALLATION METHODS

There are two typical installation methods:

- Pilot hole method for shallow installation depths
- Trench with pilot hole method for deeper installations

Each method has its own advantages and disadvantages. For more information about which installation method is best for specific applications, please contact [Customer Support](#).

2.1.5.1 METHOD 1: PILOT HOLE

METER recommends drilling an appropriately sized pilot hole with a masonry drill bit for shallow installations (less than 120 cm) to the required depth ([Figure 4](#)).

Advantages

- Minimizes the soil disturbance
- Easiest sensor removal

Disadvantages

- Sensor shaft ends and cables can be damaged
- Longer shafts may be required
- Shaft may act as a preferential water flow
- Solar radiation may heat up the sensor and may influence temperature measurements

Procedure

1. Mark the required drilling depth on the masonry drill bit ([Figure 5](#)).
2. To ensure the pilot hold is drilled correctly, use a level on the side of the drill bit to set the predetermined installation angle. ([Figure 5](#)).
3. Drill the hole until the mark on the drill bit reaches the soil surface.

OPERATION

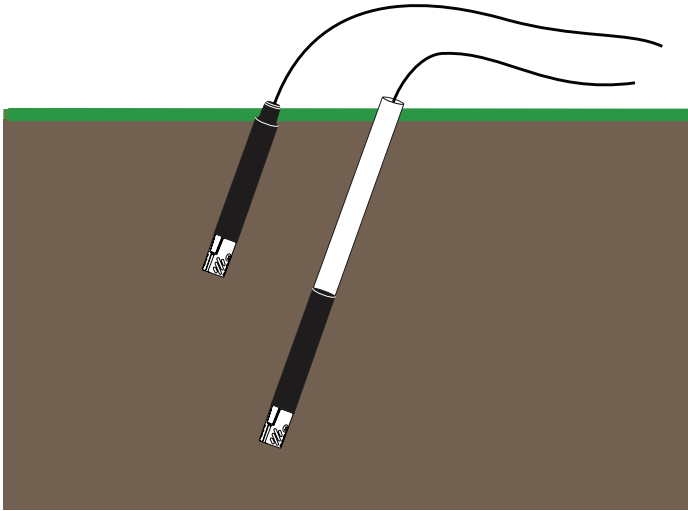

Figure 4 Pilot hole installation depths

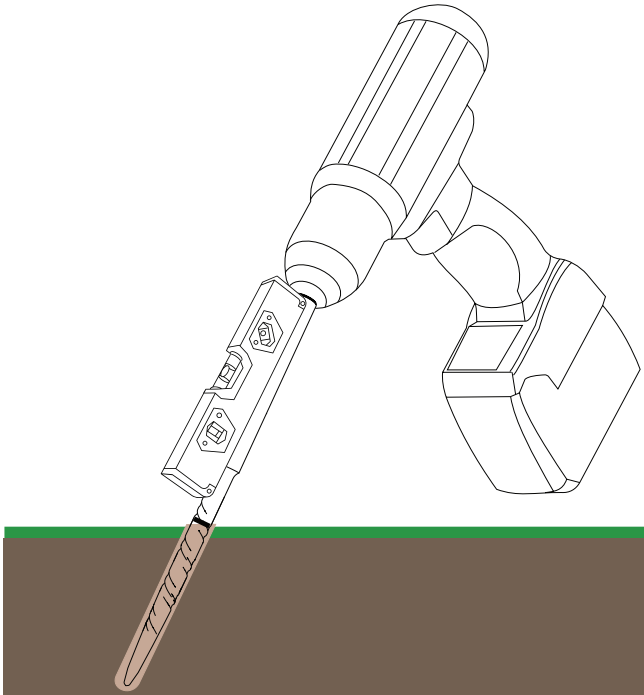

Figure 5 Drill bit and level

2.1.5.2 METHOD 2: DIG TRENCH THEN CREATE PILOT HOLE

This method is recommended if the sensor end and cables should not be exposed at the soil surface.

After digging a trench, METER recommends using a masonry drill to drill an appropriately sized pilot hole (Section 2.1.3). Installing into a trench wall may be easier than drilling the whole depth from the soil surface. When installation is finished, either fill the trench or install an irrigation valve box to house the sensor cable.

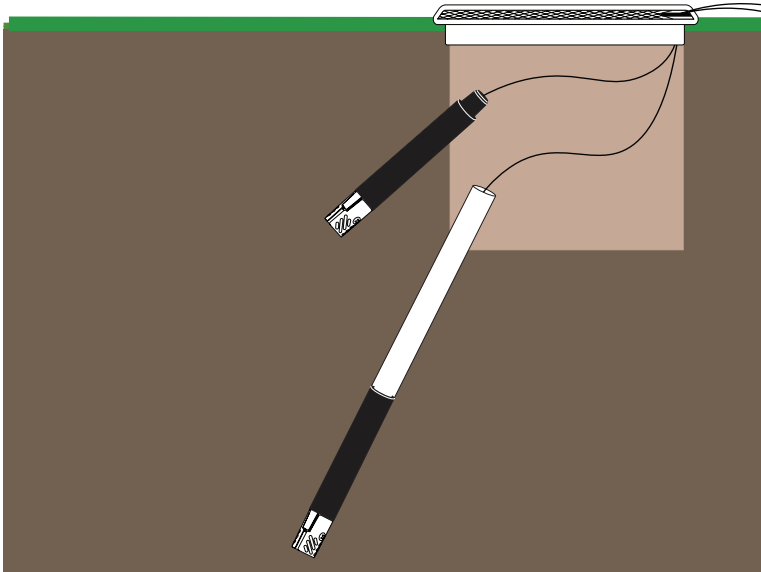

Figure 6 Pilot hole installation in trench

Advantages

- Sensor is protected from damage at the soil surface
- Installation achieved at a greater depth than the masonry drill alone reaches, reduces chance of preferential flow down sensor shaft, and minimal temperature errors from solar heating

Disadvantages

- Large soil disturbance at measurement site
- Sensor removal is more difficult
- Maintenance requires digging up the trench

For more information about which installation method is best for specific applications, please contact [Customer Support](#).

2.2 CONNECTING

The TEROS 22 works seamlessly with METER data loggers. The TEROS 22 can also be used with other data loggers, such as those from Campbell Scientific, Inc. For extensive directions on how to integrate the sensors into third-party loggers, refer to the [TEROS 22 Integrator Guide](#) (meter.ly/teros22-support).

TEROS 22 sensors require an excitation voltage in the range of 4.0 to 15 VDC and operate at a 3.6-VDC level for data communication. TEROS 22 can be integrated using DDI Serial or SDI-12 protocol. See the [TEROS 22 Integrator Guide](#) (meter.ly/teros22-support) for details on interfacing with data acquisition systems.

TEROS 22 sensors come with a 3.5-mm stereo plug connector ([Figure 7](#)) to facilitate easy connection with METER loggers ([Section 2.2.2](#)). TEROS 22 sensors may be ordered with stripped and tinned wires to facilitate connecting to some third-party loggers ([Section 2.2.3](#)).

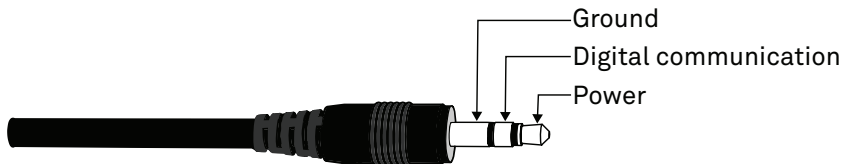

Figure 7 3.5-mm stereo plug connector

The TEROS 22 sensor comes standard with a 5-m cable. It may be purchased with custom cable lengths for an additional fee (on a per-meter basis). In some instances, the cable can be extended beyond 75 m by the user, but this is discouraged for a variety of reasons. Please contact [Customer Support](#) for more details before extending or splicing cables.

2.2.1 ADDING A CUSTOM SHAFT EXTENSION

The TEROS 22 comes standard with three optional shaft lengths of 40, 80, and 120 cm (15.7, 31.5, and 47.3 in), but it can be ordered without the standard shaft extensions if a custom length is needed. To make a customized shaft extension for the TEROS 22, use pipe sourced from a local supplier. The following pipes are suitable options for extending the shaft length:

- 3/8 schedule 40 PVC or ABS
- DN 10 mm, schedule 40
- CPVC 1/2 copper size pipe

Prepare the custom shaft and install it using the following steps:

1. Cut the pipe to the desired length to add the shaft extension onto the TEROS 22.
2. Thread the sensor cable through the pipe.
3. Attach the pipe to the sensor end using an appropriate PVC to ABS glue.

Sealing the shaft end with silicone is recommended to prevent water from being trapped in the housing.

2.2.2 CONNECT TO METER LOGGER

The TEROS 22 works most efficiently with METER ZENTRA series data loggers. Check the METER download [webpage](http://meter.ly/ZL6-support) (meter.ly/ZL6-support) for the most recent data logger firmware. Logger configuration may be done using either ZENTRA Utility (desktop and mobile application) or ZENTRA Cloud. ZENTRA Cloud is a web-based application for cell-enabled ZENTRA data loggers. More information is available on the METER [ZENTRA Cloud information page](http://meter.ly/ZENTRAcloud-info) (meter.ly/ZENTRAcloud-info).

1. Plug the stereo plug connector into one of the sensor ports on the logger.
2. Use the appropriate software application to configure the chosen logger port for the TEROS 22. METER data loggers will automatically recognize TEROS 22 sensors.
3. Set the measurement interval.

METER data loggers record the TEROS 22 measurements every minute and return the minute-average data across the chosen measurement interval.

TEROS 22 data can be downloaded from METER data loggers using either ZENTRA Utility or ZENTRA Cloud. Refer to the logger user manual for more information about these programs.

2.2.3 CONNECT TO NON-METER LOGGER

The TEROS 22 can be purchased for use with non-METER (third party) data loggers. Refer to the third-party logger manual for details on logger communications, power supply, and ground ports. The [TEROS 22 Integrator Guide](http://meter.ly/teros22-support) (meter.ly/teros22-support) provides detailed instructions on connecting sensors to non-METER loggers.

TEROS 22 sensors can be ordered with stripped and tinned (pigtail) connecting wires for use with screw terminals. Refer to the third-party logger manual for details on wiring.

Connect the TEROS 22 wires to the data logger illustrated in [Figure 8](#) and [Figure 9](#), with the supply wire (brown) connected to the excitation, the digital out wire (orange) to a digital input, and the bare ground wire to ground.

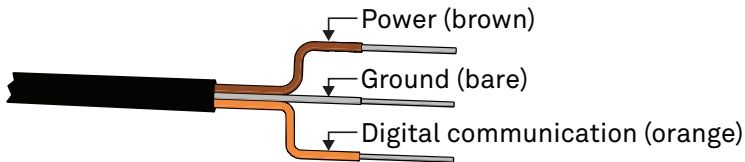

Figure 8 Pigtail wiring

OPERATION

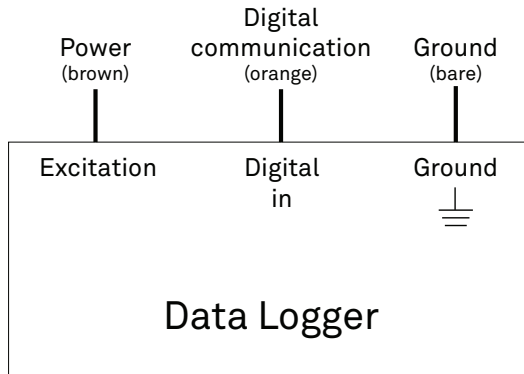

Figure 9 Wiring diagram

NOTE: The acceptable range of excitation voltages is from 4.0 to 15 VDC.

If the TEROS 22 cable has a standard stereo plug connector and needs to be connected to a non-METER data logger, use one of the following two options.

Option 1

1. Clip off the stereo plug connector on the sensor cable.
2. Strip and tin the wires.
3. Wire it directly into the data logger.

This option has the advantage of creating a direct connection and minimizes the chance of the sensor becoming unplugged. However, it then cannot be easily used in the future with a METER readout unit or data logger.

Option 2

Obtain an adapter cable from METER.

The adapter cable has a connector for the stereo plug connector on one end and three wires (or pigtail adapter) for connection to a data logger on the other end. The stripped and tinned adapter cable wires have the same termination as in [Figure 9](#): the brown wire is excitation, the orange is output, and the bare wire is ground.

NOTE: Secure the stereo plug connector to the pigtail adapter connections using adhesive-line heat shrink to ensure the sensor does not become disconnected during use.

2.3 COMMUNICATION

The SDI-12 protocol requires that all sensors have a unique address. TEROS 22 sensor factory default is an SDI-12 address of 0. To add more than one SDI-12 sensor to a bus, the sensor address can be changed using a ZSC Bluetooth® sensor interface and ZENTRA Utility Mobile app as described below:

NOTE: The sensor SDI-12 address must be returned to 0 to work with ZENTRA loggers.

TEROS 22

1. Using a mobile device, open the ZENTRA Utility Mobile app.
2. Connect the sensor to the ZSC.
3. Under **Sensor Information**, select the **SDI Address** dropdown.
4. Scroll through the options and select the desired SDI-12 address.

NOTE: Address options include 0–9, A–Z, and a–z.

Detailed information can also be found in the application note [Setting SDI-12 addresses on METER digital sensors using Campbell Scientific data loggers and LoggerNet](#).

When using the sensor as part of an SDI-12 bus, excite the sensors continuously to avoid issues with initial sensor startup interfering with the SDI-12 communications.

3. SYSTEM

This section reviews the components and functionality of the TEROS 22 sensor.

3.1 SPECIFICATIONS

MEASUREMENT SPECIFICATIONS

Water Potential

Range	0 to –100,000 kPa (1.70 to 6.00 pF)
Resolution	0.1 kPa
Accuracy	±(10% of reading + 2 kPa) from –100 to –5 kPa

NOTE: TEROS 22 can read up to 0 kPa when on a wetting path. The air entry of the soil limits the performance of the sensor to –5 kPa on the drying curve.

NOTE: TEROS 22 is not well calibrated beyond –100 kPa. For more information on using the TEROS 22 beyond this range, see [Section 3.3.3](#).

Dielectric Measurement Frequency

70 MHz

Temperature

Range	–40 to +60 °C
Resolution	0.1 °C
Accuracy	±1 °C

COMMUNICATION SPECIFICATIONS

Output

DDI Serial or SDI-12 communications protocol

Data Logger Compatibility

METER ZL6 and EM60 data loggers or any data acquisition system capable of 4.0- to 15-VDC power and serial or SDI-12 communication

PHYSICAL SPECIFICATIONS

Dimensions

Diameter	1.7 cm (0.67 in)
Length	17 cm (6.7 in)
Length with optional extensions	40, 80, and 120 cm (15.7, 31.5 and 47.3 in)

Sensor Diameter

1.7 cm (0.67 in)

Operating Temperature Range

Minimum -40 °C

Typical NA

Maximum +60 °C

NOTE: Sensors may be used at higher temperatures under certain conditions; contact [Customer Support](#) for assistance.

Cable Length

5 m (standard)

75 m (maximum custom cable length)

NOTE: Contact [Customer Support](#) if a nonstandard cable length is needed.

Cable Diameter

4.2 mm (0.165 in)

Connector Types

Stereo plug connector or stripped and tinned wires

Connector Size

3.50 mm

Conductor Gage

22-AWG / 24-AWG ground wire

ELECTRICAL AND TIMING SPECIFICATIONS**Supply Voltage (power to ground)**

Minimum 4.0 VDC

Typical NA

Maximum 15.0 VDC

Digital Communication Input (logic high)

Minimum 2.8 V

Typical 3.6 V

Maximum 5.0 V

SYSTEM

Digital Communication Input (logic low)

Minimum	-0.3 V
---------	--------

Typical	0.0 V
---------	-------

Maximum	0.8 V
---------	-------

Digital Communications Output (logic high)

Minimum	NA
---------	----

Typical	3.6 V
---------	-------

Maximum	NA
---------	----

Required Supply Current

Minimum	15mA
---------	------

Typical	NA
---------	----

Maximum	NA
---------	----

Required Power Supply Slew Rate

Minimum	1.0 V/ms
---------	----------

Typical	NA
---------	----

Maximum	NA
---------	----

Time to Start of DDI Serial Message

Minimum	NA
---------	----

Typical	100 ms
---------	--------

Maximum	350 ms
---------	--------

Time before sensor is responsive to SDI-12 commands (DDI serial enabled)

Minimum	NA
---------	----

Typical	260 ms
---------	--------

Maximum	500 ms
---------	--------

Time before sensor is responsive to SDI-12 commands (DDI serial disabled)

Minimum	NA
---------	----

Typical	170 ms
---------	--------

Maximum	NA
---------	----

Measurement Duration	
Minimum	NA
Typical	50 ms
Maximum	NA

COMPLIANCE

EM ISO/IEC 17050:2010 (CE Mark)

EN 55011:2016 / A1:2017 (RCM Mark)

3.2 COMPONENTS

The TEROS 22 sensor measures the water potential and temperature of soil with porous ceramic discs (Figure 10). TEROS 22 sensors measure moisture content changes of two engineered ceramic discs sandwiched between stainless steel screens and the circuit board. These sensors have a low power requirement that makes them ideal for permanent burial in the soil and continuous reading with a data logger or periodic reading with a handheld reader.

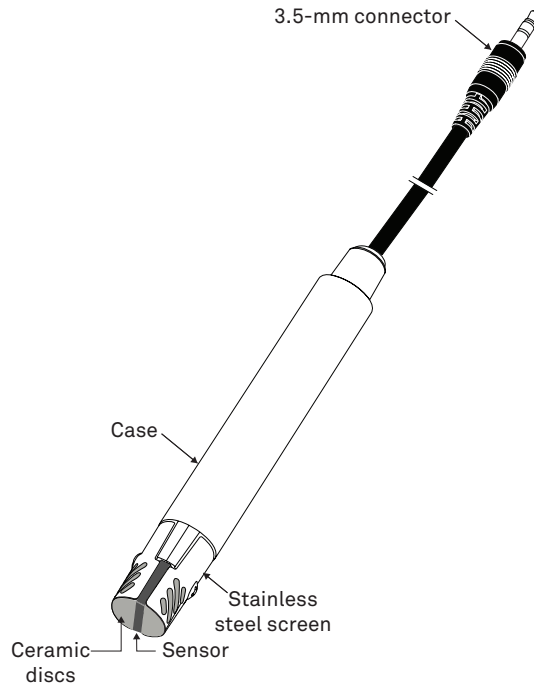

Figure 10 TEROS 22 sensor

3.3 THEORY

TEROS 22 sensors measure water potential, so they are not as sensitive to soil disturbance as water content sensors. TEROS 22 requires good hydraulic contact with the surrounding soil for accurate measurements.

3.3.1 WATER POTENTIAL MEASUREMENT

All soil water potential measurement techniques measure the potential energy of water in equilibrium with water in the soil. The Second Law of Thermodynamics states that connected systems with differing energy levels move toward an equilibrium energy level. When an object comes into hydraulic contact with the soil, the water potential of the object comes into equilibrium with the soil water potential.

TEROS 22 uses a solid matrix equilibration technique to measure the water potential of the soil. This technique introduces a material with a known pore size distribution into the soil and allows it to come into hydraulic equilibrium according to the Second Law of Thermodynamics. Because the two are in equilibrium, measuring the water potential of the solid matrix gives the water potential of the soil.

TEROS 22 measures the dielectric permittivity of a solid matrix (porous ceramic discs) to determine its water potential. The dielectric permittivity of air, the solid ceramic, and water are 1, 5, and 80, respectively. So, the dielectric permittivity of the porous ceramic discs is highly dependent on the amount of water present in the pore spaces. Measuring the dielectric permittivity of the ceramic discs resolves a wide range of water content measurements.

Water content and water potential are related by a relationship unique to a given material, called the moisture characteristic curve. The ceramic used with the TEROS 22 has a wide pore-size distribution and is consistent between discs, giving each disc the same moisture characteristic curve. Thus, the water potential can be inferred from water content using the moisture characteristic curve of the ceramic

Equation 2 gives the component variables for determining total soil water potential (Ψ_t):

$$\psi_t = \psi_p + \psi_g + \psi_o + \psi_m \quad \text{Equation 2}$$

where Ψ_p is pressure, Ψ_g is gravitational, Ψ_o is osmotic, and Ψ_m is matric.

For TEROS 22 applications, Ψ_p and Ψ_g are generally insignificant. Ψ_o arises from dissolved salts in the soil and only becomes important if a semipermeable barrier is present that prevents ionic movement (e.g., plant roots or cell membranes). Ψ_m arises from the attraction of water to the soil particles and is the most important component of water potential in most soils. TEROS 22 responds to the matric potential of the soil (Ψ_m). In highly salt-affected soils, it may be necessary to quantify Ψ_o independently if the measurements of soil water potential are related to biological activity (Section 3.4.2).

3.3.2 MEASUREMENT RANGE

TEROS 22 measures the water content of porous ceramic discs and converts the measured water content to water potential using the moisture characteristic curve of the ceramic. Therefore, it is important that the ceramic discs drain over a wide water potential range. Pore size determines the water potential at which a pore drains (the air entry potential or bubble pressure), so the ideal ceramic would have pores that range from very small to relatively large. METER designed the ceramic discs to approach this ideal. The discs have a total pore volume that is weighted toward the larger pores, which drain at water potentials within the plant-available range (approximately -33 to $-2,000$ kPa).

DRY-END LIMITATIONS

As the sensor dries past the plant-available range, the total pore volume that drains at a given water potential decreases. At these low water potentials, the measured water potential can become somewhat noisy because small changes in measured water content of the ceramic translate into large changes in water potential. This phenomenon is most pronounced when the sensor is air dry. It is expected that the measured water potential of a dry sensor open to the air can jump around significantly. The noise level is much lower when the sensor is installed in the soil, even at air-dry water potential.

WET-END LIMITATIONS

The air entry potential of the largest pores in the ceramic is about -5 kPa. However, the ceramic disc must have access to air for the large pores to begin draining and the response of the sensor to change. If the soil around the sensor has an air entry potential lower (drier) than -5 kPa, the ceramic will not begin to lose water until reaching the air entry potential of the soil. In this scenario, the air entry potential of the soil limits the wet-end range, rather than the ceramic discs themselves. The sensor may not begin to respond until lower water potentials. This is generally only an issue when using the sensor in poorly structured soils with high clay content.

3.3.3 MEASUREMENT ACCURACY

TEROS 22 is calibrated at a saturated state (0 kPa), at a dry state equivalent to $-100,000$ kPa, and at four calibration points between 0 and -100 kPa, resulting in accuracy of $\pm(10\%$ of reading + 2 kPa) over the range of -5 to -100 kPa.

At water potentials drier than -100 kPa, TEROS 22 relies on the linear relationship between water content and the logarithm of water potential. Independent field evaluations have shown low sensor-to-sensor variability down to permanent wilting point ($-1,500$ kPa) as shown in [Figure 11](#).

NOTE: METER strongly discourages dry-end calibrations of the TEROS 22 in the pressure plate apparatus. Early attempts to improve sensor dry-end performance in the pressure plate apparatus actually decreased accuracy, likely because of pressure plate dry-end equilibrium issues pointed out in the literature (e.g., Campbell [1988], Gee et al. [2002], Bittelli and Flury [2009], and Frydman and Baker [2009]).

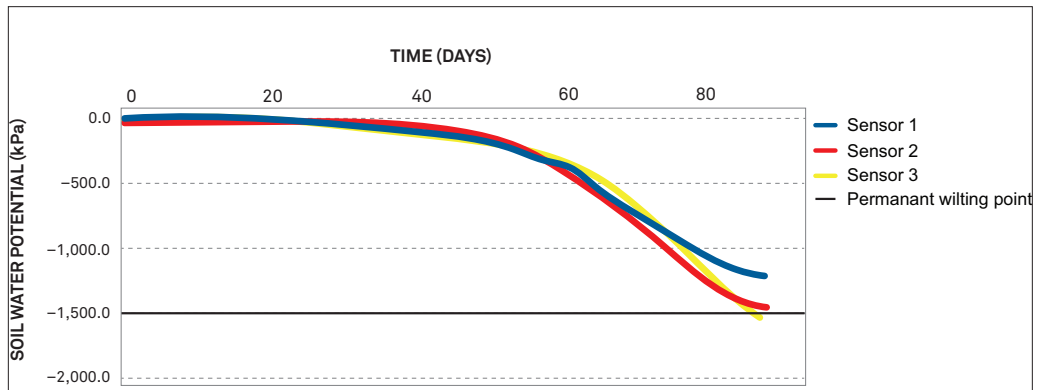

Figure 11 Time series TEROS 22 water potential data collected at 80-cm depth under a beech forest in Switzerland (Walthert, 2024)

3.3.4 TEMPERATURE MEASUREMENT

TEROS 22 uses a surface-mounted thermistor to take temperature readings. The thermistor is located underneath the sensor epoxy. The TEROS 22 output temperature readings in degrees Celsius unless otherwise stated in preference settings in METER software programs. If the black plastic body of the sensor is exposed to solar radiation, the temperature measurement may read high. Do not install the sensor with the black body above ground. The shaft extension piece on the TEROS 22 are white to minimize potentiating heating and can be installed with some of the extension piece above ground. However, any part of the shaft extension exposed above ground should be protected from damp and insulating the shaft will help minimize impacts on temperature measurements.

3.4 CONSIDERATIONS

TEROS 22 sensors use similar technology to other METER water content sensors. METER water content and water potential sensors are susceptible to the same constraints. Using the TEROS 22 in certain environments will require additional considerations.

3.4.1 MEASURING IN FROZEN SOILS

TEROS 22 measures the dielectric permittivity of two ceramic discs to measure their water content and then derive their water potential. The dielectric permittivity of water in the ceramic discs is 80 compared to a dielectric permittivity of ~5 for the ceramic material or 1 for air. When water freezes to ice, the dielectric permittivity drops to 5 at the frequency of the sensor measurement, meaning that the sensor can no longer accurately measure the water in the ceramic.

TEROS 22 does not accurately measure water potential in frozen soil conditions. However, the water potential of the soil under frozen soil conditions can be estimated by measuring the soil temperature accurately (Koopmans and Miller, 1966). For each 1 °C decrease in

temperature below 0 °C, the water potential in the soil decreases by ~1,200 kPa. Spaans and Baker (1996) showed that this relationship is valid in field soils for water potentials below about -50 kPa.

Rigorous testing indicates that repeated freeze–thaw cycles do not affect the ceramic discs. Several sensors were equilibrated in saturated soil and then subjected to numerous freeze–thaw cycles in a temperature-controlled chamber. The freezing rate of the soil containers was at least an order of magnitude faster than could be achieved in field soils under natural conditions. At several points during the test, and at the end of the test, the ceramic discs were evaluated for damage due to repeated rapid freezing of pore spaces full of water. None of the ceramic discs showed any signs of physical damage, and none of the sensors showed any significant change in output due to the freeze–thaw tests.

3.4.2 MEASURING IN HIGH SALINITY

A saturation extract electrical conductivity (EC) greater than 10 dS/m will confound the capacitance measurement taken by the sensor resulting in erroneous matric potential readings. It is recommended that the TEROS 22 only be used in environments where the saturation extract EC does not exceed 10 dS/m.

3.4.3 TEMPERATURE SENSITIVITY

Fluctuations in temperature can affect the capacitance readings at matric potential less than about -500 kPa (Figure 12). Although temperature can affect the output of the reading, the nature of the moisture retention curve of the ceramic results in an extremely small effect on matric potential until the substrate dries out to about -500 kPa. A small change in water content can result in a relatively large change in matric potential beyond -500 kPa.

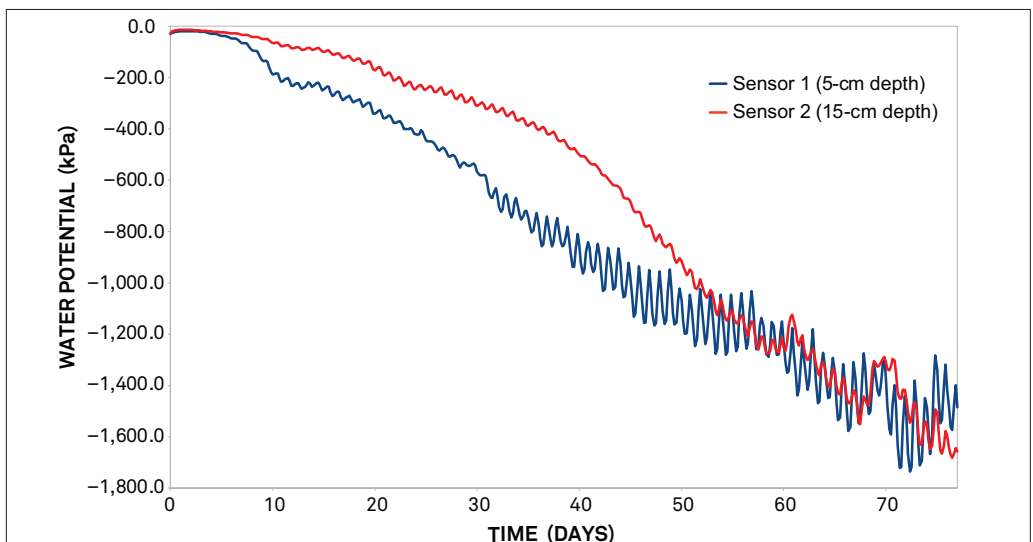

Figure 12 Temperature sensitivity data for TEROS 22 sensors

4. SERVICE

This section describes the calibration and maintenance of TEROS 22. Troubleshooting solutions and customer service information are also provided.

4.1 CALIBRATION

TEROS 22 calibration is not affected by soil type because the sensors only measure the water potential of the ceramic discs in equilibrium with the soil. TEROS 22 works in any soil type or other porous media as long as it is installed correctly with adequate hydraulic contact (to ensure timely water potential equilibrium between the sensor and the medium of interest).

The amount of water that a soil holds at a given water potential is greater if the material is dried to that water potential than if the material is wet up to that water potential; a phenomenon known as hysteresis. Because TEROS 22 essentially makes a dielectric measurement of water content and converts that to water potential, sensor measurements have some hysteresis. In most situations, soil undergoes brief periods of wet up (precipitation or irrigation events) followed by longer dry down periods, where water potential measurements are most useful. METER performs TEROS 22 calibration on the drying leg of the hysteresis loop, so the measurements are most accurate as the soil dries. Measurements as the soil wets up are slightly drier (more negative water potential) than the true water potential of the soil. METER wetting and drying tests show the magnitude of the hysteresis error is <10 kPa in the -20 to -100 kPa range.

4.2 MAINTENANCE

TEROS 22 may be returned to METER for maintenance in the following areas: system inspection, parts replacement, and instrument cleaning. Replacement parts can also be ordered from METER. Contact [Customer Support](#) for more information.

The ceramic discs are brittle and can chip or crack if abused. The metal screens afford the discs some amount of protection, but sharp trauma on the disc edges or massive impact (such as dropping the sensor onto a hard surface) can cause the ceramic to break. One or two small chips on the edge of the disc do not affect the sensor accuracy significantly. However, a cracked ceramic disc results in a loss of accuracy.

For TEROS 22 to accurately measure water potential, the ceramic discs must readily take up water. Exposure to oils or other hydrophobic substances compromises the ability of the discs to take up water from the soil. This inability to take up water leads to slow equilibration times and loss of accuracy. Minimize exposure of the ceramic material to skin oils, grease, synthetic oils, or other hydrophobic compounds.

4.3 TROUBLESHOOTING

Table 2 lists common problems and their solutions. Most issues with the TEROS 22 sensor will manifest themselves in the form of incorrect or erroneous readings. If the problem is not listed or these solutions do not solve the issue, contact [Customer Support](#).

Table 2 Troubleshooting TEROS 22

Problem	Possible Solutions
Data logger is not recognizing sensor	If using a METER logger, update logger firmware.
Data logger is not receiving readings from the sensor	<p>Check to make sure the connections to the data logger are both correct and secure.</p> <p>Ensure that your data logger batteries are not dead or weakened.</p> <p>Check configuration of data logger through software to ensure TEROS 22 is selected.</p> <p>Ensure the software and firmware is up to date.</p>
Sensor does not appear to be responding to changes in soil water potential	<p>Ensure that sensors are installed correctly.</p> <p>Check sensor cables for damage that could cause a malfunction.</p> <p>Check the ceramic disc for damage or contamination.</p>

4.4 CUSTOMER SUPPORT

NORTH AMERICA

Customer service representatives are available for questions, problems, or feedback Monday through Friday, 7:00 am to 5:00 pm Pacific time.

Email: support.environment@metergroup.com
sales.environment@metergroup.com

Phone: +1.509.332.5600

Fax: +1.509.332.5158

Website: metergroup.com

EUROPE

Customer service representatives are available for questions, problems, or feedback Monday through Friday, 8:00 to 17:00 Central European time.

Email: support.europe@metergroup.com
sales.europe@metergroup.com

Phone: +49 89 12 66 52 0

Fax: +49 89 12 66 52 20

Website: metergroup.com

If contacting METER by email, please include the following information:

Name	Email address
Address	Instrument serial number
Phone	Description of the problem

NOTE: For products purchased through a distributor, please contact the distributor directly for assistance.

4.5 TERMS AND CONDITIONS

By using METER instruments and documentation, you agree to abide by the METER Group, Inc. Terms and Conditions. Please refer to metergroup.com/terms-conditions for details.

REFERENCES

- Bittelli, Marco, and Markus Flury. 2009. "Errors in Water Retention Curves Determined with Pressure Plates." *Soil Science Society of America Journal* 73 (5): 1453–60. <https://doi.org/10.2136/sssaj2008.0082>Citations: 124.
- Campbell, Gaylon S. 1988. "Soil Water Potential Measurement: An Overview." *Irrigation Science* 9: 265–73. <https://doi.org/10.1007/BF00296702>.
- Frydman, Samuel, and Rafi Baker. 2009. "Theoretical Soil-Water Characteristic Curves Based on Adsorption, Cavitation, and a Double Porosity Model." *International Journal of Geomechanics, Technical Papers*, 9 (6): 1532–3641. [https://doi.org/10.1061/\(ASCE\)1532-3641\(2009\)9:6\(250\)](https://doi.org/10.1061/(ASCE)1532-3641(2009)9:6(250)).
- Gee, Glendon W., Andy L. Ward, Zhang F. Zhuanfang, Gaylon S. Campbell, and Jon B. Mathison. 2002. "The Influence of Hydraulic Nonequilibrium on Pressure Plate Data." *Vadose Zone Journal, Soil Science Society of America*, 1 (1): 172–78. <https://doi.org/10.2136/vzj2002.1720>.
- Koopmans, Ruurd Willen Rienk, and Robert D. Miller. 1966. "Soil Freezing and Soil Water Characteristics Curves." *Soil Science Society of America Journal, Soil Physic*, 30 (6): 680–85. <https://doi.org/10.2136/sssaj1966.03615995003000060011x>.
- Spaans, Egbert J. A., and John M. Baker. 1996. "The Soil Freezing Characteristic: Its Measurement and Similarity to the Soil Moisture Characteristic." *Soil Science Society of America Journal, Soil Physic*, 60 (1): 13–19. <https://doi.org/10.2136/sssaj1996.03615995006000010005x>.
- Walthert, Lorenz, and Swiss Federal Institute for Forest, Snow, and Landscape WSL Research. 2013. "Soil as a site factor in Swiss forests (project title)." Climate change research project 2010–2025. Soil Functions and Soil Protection. Birmensdorf, Switzerland: Swiss Federal Institute WSL Research. <https://www.wsl.ch/en/projects/soil-as-a-site-factor.html>.

INDEX

- C**
- cable colors **10**
 - calibration **18, 21**
 - ceramic pore size **19–20**
 - cleaning. *See* maintenance
 - components
 - ceramic discs **16, 17, 18–19, 21, 22**
 - circuit board **16**
 - screens **16, 21**
 - sensor body **16, 19**
 - connecting **9–12, 22**
 - customer support **22**
- E**
- electrical conductivity **20**
 - email address **22, 23**
- F**
- fax number **22, 23**
- H**
- hydraulic equilibrium **17, 21**
 - hysteresis **21**
- I**
- installation **19**
 - angle **5**
 - connecting **9–12**
- L**
- limitations
 - dry-end limitations **18**
 - measuring in high salinity **17, 20**
 - temperature sensitivity **20**
 - wet-end limitations **18–19**
- M**
- maintenance **21**
 - matric potential **17, 20**
 - moisture characteristic curve **18–19**
- P**
- phone number **22, 23**
- R**
- references **24**
- S**
- specifications **13–14**
- T**
- temperature **16, 19**
 - terms and conditions **23–24**
 - theory
 - dielectric permittivity **17, 19**
 - dry-end limitations **18**
 - measurement accuracy **18–19**
 - measurement range **18–19**
 - measuring in frozen soil **19–20**
 - measuring in high salinity **17, 20**
 - moisture characteristic curve **17, 18**
 - temperature measurement **19**
 - temperature sensitivity **20**
 - water potential **17**
 - wet-end limitations **18–19**
 - troubleshooting **22**
- W**
- water content **17, 18, 21**
 - water potential **18, 21**. *See also* moisture characteristic curve; *See also* ceramic pore size
 - measurement **17, 22**

METER Group, Inc.

2365 NE Hopkins Court Pullman, WA 99163
T: +1.509.332.2756 F: +1.509.332.5158
E: info@metergroup.com W: metergroup.com

METER Group GmbH

Mettlacher Straße 8, 81379 München
T: +49 89 1266520 F: +49 89 12665220
E: info.europe@metergroup.com W: metergroup.de

