



METER

MAS-1



TABLE OF CONTENTS

1. Introduction	1
2. Operation	2
2.1 Installation	2
2.2 Removal	3
2.3 Connecting	3
2.3.1 Conventional (PLC)	4
2.3.2 Nonconventional	5
2.3.3 Testing the Sensor	6
3. System	7
3.1 Specifications	7
3.2 Components	9
4. Service	10
4.1 Calibration	10
4.1.1 Mineral Soils	10
4.1.2 Potting Soil/Peat	10
4.1.3 Rockwool	10
4.2 Troubleshooting	11
4.3 Customer Support	11
4.4 Terms and Conditions	12
Index	13

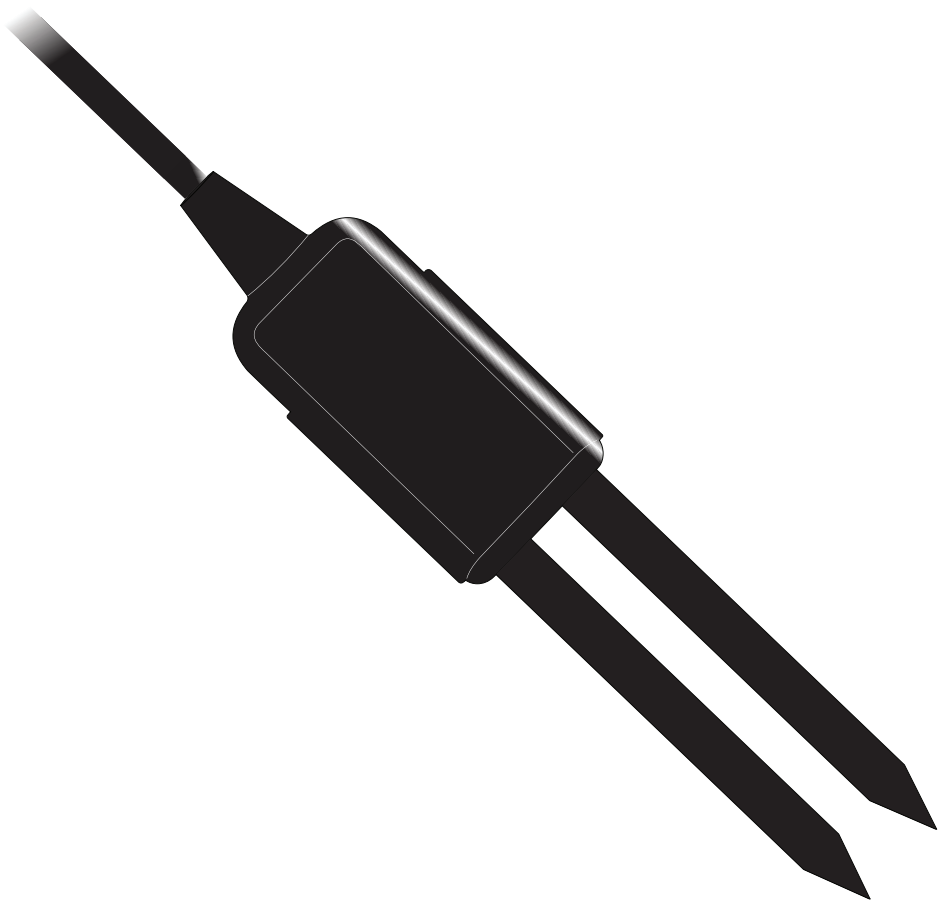

1. INTRODUCTION

Thank you for choosing the MAS-1 Soil Moisture Sensor from METER Group. This innovative sensor monitors soil moisture accurately with a standard 2-wire, 4- to 20-mA analog interface for use with many data acquisition and control systems. The MAS-1 cannot be used with the standard METER data loggers.

Prior to use, verify the sensor arrived in good condition.

2. OPERATION

Please read all instructions before operating the MAS-1 to ensure it performs to its full potential.

PRECAUTIONS

METER sensors are built to the highest standards, but misuse, improper protection, or improper installation may damage the sensor and possibly void the manufacturer's warranty. Before integrating MAS-1 into a system, make sure to follow the recommended installation instructions and have the proper protections in place to safeguard sensors from damage.

2.1 INSTALLATION

The MAS-1 sensor was designed for easy installation into the soil. When selecting a site, consider several factors. First, the soil adjacent to the sensor surface has the strongest influence on the sensor reading and that the sensor measures the volumetric water content (VWC). Therefore, any air gaps or excessive soil compaction around the sensor can profoundly influence the readings. Second, do not install the sensors adjacent to large metal objects, such as metal poles or stakes. This can attenuate the sensor electromagnetic field and adversely affect the sensor readings. Third, material may become stuck between the sensor prongs, such as sticks, bark, roots or other material, which will adversely affect readings. Finally, be careful when inserting the sensors into dense soil, as the prongs will break if excessive sideways force is used when inserting them.

The sensor can be oriented in any direction. However, orienting the side perpendicular to surface of the soil minimizes effects on downward water movement. [Figure 1](#) shows examples of sensor installation orientations.

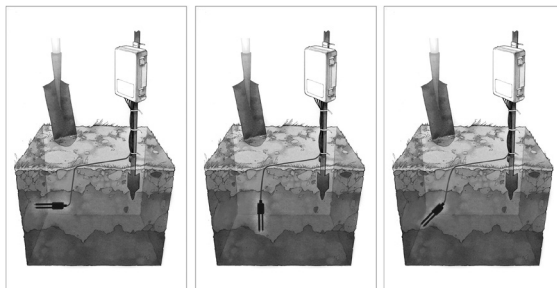

Figure 1 Installation orientation

1. Dig a hole to the desired depth.
2. Gently push the sensor prongs into undisturbed soil either at the bottom or side of the hole. Ensure the prongs are buried completely to the black overmolding.

The sensor may be difficult to insert into extremely compact or dry soil. Try loosening or wetting the soil to help the sensor push in more easily.

NOTE: Never pound the sensor into the ground.

- Carefully backfill the hole to match the bulk density of the surrounding soil. Be careful to not over stress the cable or over mold by bending when installing the sensor.

2.2 REMOVAL

When removing the sensor from the soil, do not pull it out of the soil by the cable! Doing so may break internal connections and make the sensor unusable.

2.3 CONNECTING

A 4- to 20-mA system generally consists of a sensor, transmitter, power supply, and device to read the current being transmitted through the current loop. The MAS-1 is an integrated sensor and 4- to 20-mA transmitter. When the MAS-1 is powered by the power supply, it transmits a current through the loop that is proportional to the soil dielectric permittivity and therefore the soil VWC. In [Figure 2](#), the current loop is shown by the dotted line. The arrows indicate the direction of the current.

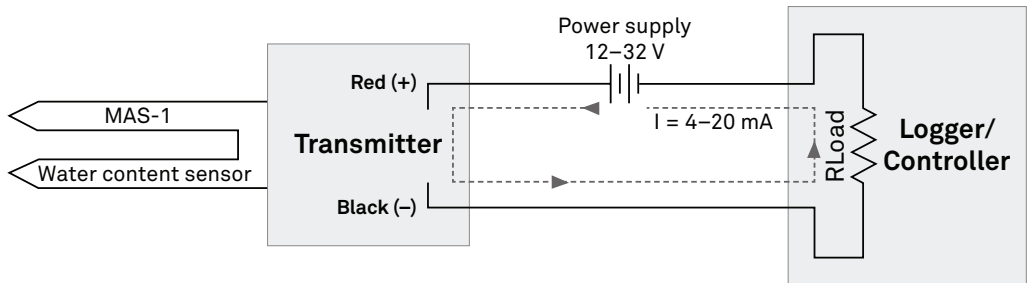

Figure 2 4-20 mA current loop diagram

The MAS-1 will operate with a power supply from 12 to 32 V. It will perform best when powered with a square power curve. If the rise time to reach the supply voltage is too long, the MAS-1 can experience measurement processing problems. METER recommends reaching the target power supply voltage within 10 ms for best performance. Refer to [Figure 3](#) for an ideal power curve for the MAS-1.

OPERATION

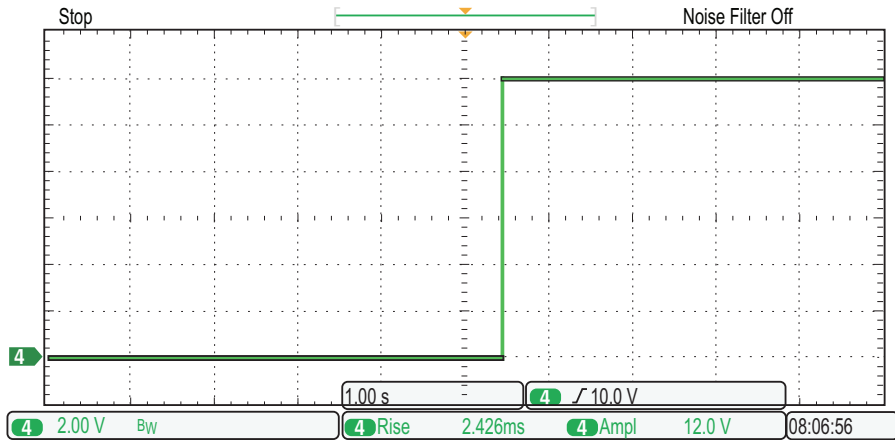

Figure 3 Recommended rise time for MAS-1 power supply

The MAS-1 uses a microcontroller to regulate the measurement interval. It takes 1 s from the time it is powered up to take its first measurement and transmit current through the loop. The transmitted current will reach a stable value within 4 s of power up. After the initial 4-s startup, measurements are taken every 1 s, while the current in the loop is continuously maintained. Since the measurement intervals are controlled by the MAS-1 itself, there is no need to pulse the excitation voltage. A constant supply voltage should be applied in order for the MAS-1 to function properly.

2.3.1 CONVENTIONAL (PLC)

A programmable logic controller (PLC) is typically used to read the current transmitted through the MAS-1. The red wire (Figure 4) of the MAS-1 is connected to a voltage output terminal that is able to supply 12 to 32 VDC. The black wire is connected to an input terminal that accepts a current input ranging from 4 to 20 mA. For the MAS-1 to function properly, the voltage drop from the red to the black lead must be 12 V or greater.

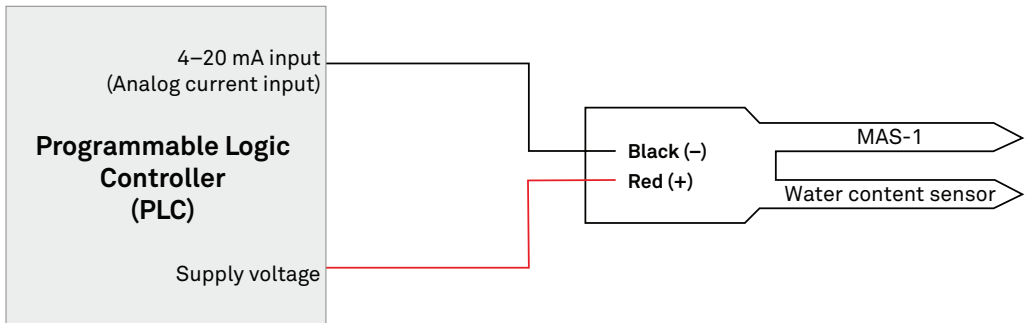

Figure 4 Typical wiring connection

2.3.2 NONCONVENTIONAL

When using a device, such as a data logger, that does not have an input capable of measuring current, a pickoff resistor can be used as shown in [Figure 5](#). Assuming that the single-ended input has an input impedance, or resistance, much larger than of $R_{V_{olt}}$, then all of the current in the 4 to 20 mA loop passes through $R_{V_{olt}}$. If the data logger can measure the voltage drop over the $R_{V_{olt}}$, then the current can be calculated as shown in [Equation 1](#):

$$I = \frac{V_{measured}}{R_{V_{olt}}}$$

Equation 1

where I (in milliamperes) is the 4 to 20 mA current, $R_{V_{olt}}$ (in ohms) is the resistance of the pickoff resistor, and $V_{measured}$ (in millivolts) is the voltage drop over $R_{V_{olt}}$.

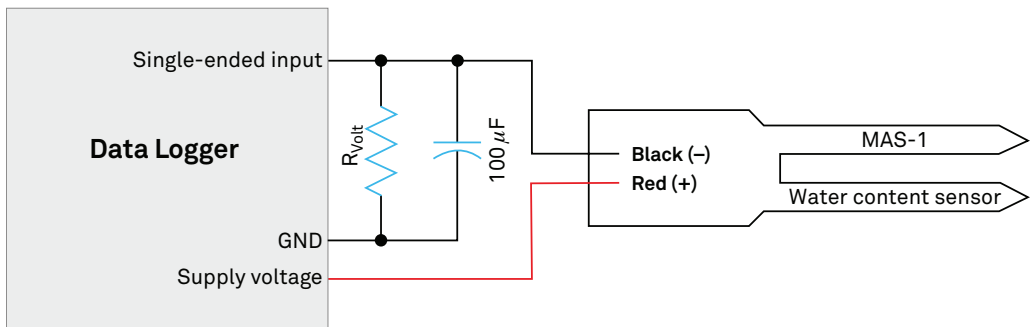

Figure 5 Wiring connection for devices without current

The optional 100 µF capacitor shown in parallel with the $R_{V_{olt}}$ reduces measurement noise. It should have a voltage rating higher than the largest supply voltage. Be sure to observe correct polarity. The MAS-1 requires a voltage of at least 12 V. This limits the value of $R_{V_{olt}}$ since part of the total voltage drop will be across the resistor. [Equation 2](#) can be used to determine the maximum value for $R_{V_{olt}}$. [Table 1](#) shows time resistance values.

$$V_{supply} - 12 = 0.02 R_{V_{oltMax}}$$

Equation 2

Table 1 Maximum resistance values for $R_{V_{olt}}$ at specified voltages

Supply Voltage	Load
13 V	50 Ω
24 V	600 Ω
32 V	1,000 Ω

OPERATION

1. The supply voltage does not need to be regulated for the sensor to work properly; it can be any value between 12 and 32 V, without affecting sensor output.
2. The signal is not affected by electrical resistance in the cable, so the sensor output is not affected by cable length or wire gauge.
3. The MAS-1 requires only two conductors, so long lines are both lower in noise and less expensive.
4. The source impedance is small, and a current loop is highly immune to noise on the line.
5. Measured voltage can be tailored to a particular data acquisition system simply by adjusting the value of R_{volt} . A typical application might be to use a MAS-1 with a 12-V supply and an R_{volt} value of $1\ \Omega$. The output voltage range is the product of the current and the resistance (Equation 1), so it would be 4 to 20 mA for 4 to 29 mV.

2.3.3 TESTING THE SENSOR

After integrating the MAS-1 into the data acquisition system, test the sensor output to verify it is functioning correctly with the system. Two convenient test conditions are surrounding the sensor with either air or water.

- To test in air, suspend the sensor from the cable, at least 15.25 cm (6 in) from any object. The sensor should transmit between approximately 3.4 to 4.7 mA.
- To test in water, place the sensor in a bucket of tap water (do not use deionized or distilled water). The entire sensor (prongs and black sensor body) should be immersed in water, and should be at least 5 cm (2 in) from any container surface. The sensor should transmit between approximately 18.1 to 22.4 mA.

NOTE: Sensor output can go above 20 mA and below 4 mA.

3. SYSTEM

This section describes the MAS-1 Soil Moisture Sensor.

3.1 SPECIFICATIONS

MEASUREMENT SPECIFICATIONS

Volumetric Water Content (VWC)

Range	0–0.57 m ³ /m ³ , calibration dependent (0–100% VWC possible with custom calibration)
Resolution	Depends on current data acquisition device
Accuracy	6% VWC with generic calibration for supported growing media up to 65% VWC, above which accuracy lessens Increased accuracy can be achieved with a medium-specific calibration. Contact Customer Support .

Dielectric Measurement Frequency

70 MHz

COMMUNICATION SPECIFICATIONS

Output

4–20 mA current proportional to VWC

Data Logger Compatibility

Data acquisition system capable of constant 12–32 VDC supply and 4–20 mA current measurement.

PHYSICAL SPECIFICATIONS

Dimensions

Length	8.9 cm (3.5 in)
Width	1.8 cm (0.7 in)
Height	0.7 cm (0.3 in)

Prong Length

5 cm (1.97 in)

Operating Temperature Range

Minimum	-40 °C
Typical	NA
Maximum	60 °C

NOTE: Sensors may be used at higher temperatures under certain conditions; contact [Customer Support](#) for assistance.

Cable Length

5 m (standard)
40 m (maximum custom cable length)

NOTE: Contact [Customer Support](#) if a nonstandard cable length is needed or if cables longer than 40 m are desired.

Connector Types

Stripped and tinned wires

ELECTRICAL AND TIMING CHARACTERISTICS**Supply Voltage (VIN to GND)**

Minimum	12 VDC continuous
Typical	NA
Maximum	32 VDC continuous

Power Line Slew Rate

Minimum	1.0 V/ms
Typical	NA
Maximum	NA

Measurement Duration

Minimum	NA
Typical	1.0 s
Maximum	NA

COMPLIANCE

EM ISO/IEC 17050:2010 (CE Mark)
2004/208/EC; 2011/65/EU
EN61326-1:2013; EN61321:2009

3.2 COMPONENTS

The MAS-1 measures the capacitance of the soil to find its volumetric water content (VWC). Since the capacitance of water is much higher than that of air or soil minerals, the capacitance of the soil is a sensitive measure of water content. The MAS-1 supplies a 70-MHz oscillating wave to the sensor prongs that induces an electromagnetic field in the medium (soil) surrounding the sensor. The charging and discharging of the sensor is controlled by the dielectric of the surrounding soil.

The microprocessor makes a dielectric measurement and updates the transmitted current once per second. The transmitted 4- to 20-mA current can be converted to the water content of the soil using a simple calibration function. The MAS-1 is designed to be used with standard 4-to 20-mA controllers and monitoring systems. It cannot be used with METER data loggers. For more information about using METER data loggers, please contact [Customer Support](#).

4. SERVICE

This section contains calibration information, customer support contact information, and terms and conditions.

4.1 CALIBRATION

The current transmitted by the MAS-1 is proportional to the dielectric permittivity of the medium surrounding the sensor and therefore the VWC of the medium. The VWC is calculated by applying a calibration equation to the current transmitted by the MAS-1. The following are generic calibration equations for common growth media. Applying these equations will generally result in accuracy of 6% VWC as long as the electrical conductivity of the medium is less than 8 dS/m. If the MAS-1 needs to be used in an unlisted medium, the application requires a more than 6% accuracy, or the material has high salinity, contact [Customer Support](#) to discuss a custom calibration.

4.1.1 MINERAL SOILS

A single calibration equation will generally result in good accuracy for all mineral soil types with electrical conductivity less than 8 dS/m. VWC is given by [Equation 3](#):

$$VWC = 0.00328 \times mA^2 - 0.0244 \times mA - 0.00565 \quad \text{Equation 3}$$

If the data acquisition system is not capable of higher order mathematical operations, the mineral soil calibration can be approximated by the linear model shown in [Equation 4](#). This will result in slightly worse accuracy at low VWC, with errors becoming large above 35% VWC.

$$VWC = 0.0479 \times mA - 0.391 \quad \text{Equation 4}$$

4.1.2 POTTING SOIL/PEAT

The [Equation 5](#) can be used to convert MAS-1 transmitted current into VWC in potting soil and peat potting mixes. Please note that different potting soil types are quite variable, so this calibration equation may not result in good accuracy in every particular mix (although precision should still be good). METER recommends a custom calibration for best accuracy when using the MAS-1 in potting soils.

$$VWC = 0.00531 \times e^{(0.29 \times mA)} \quad \text{Equation 5}$$

4.1.3 ROCKWOOL

The MAS-1 was calibrated in Grodan Expert™ rockwool at several electrical conductivities. VWC can be calculated as shown in [Equation 6](#):

$$VWC = 0.00446 \times mA^2 - 0.0359 \times mA + 0.0741 \quad \text{Equation 6}$$

4.2 TROUBLESHOOTING

Table 2 lists common problems and their solutions. If the problem is not listed or these solutions do not solve the issue, contact [Customer Support](#).

Table 2 Troubleshooting the MAS-1

Problem	Possible Solutions
Readings are outside expected ranges	<p>Check the connection to the PLC or other data acquisition system.</p> <p>Check the wiring and make sure that the supply voltage is in the specified range.</p>
Readings are negative while in soil	<p>Ensure good sensor-to-soil contact. When inserted, the MAS-1 should be completely covered up past the black sensor body.</p> <p>Removing and reinstalling should remedy this problem.</p>

4.3 CUSTOMER SUPPORT

NORTH AMERICA

Customer service representatives are available for questions, problems, or feedback Monday through Friday, 7:00 am to 5:00 pm Pacific time.

Email: support.environment@metergroup.com
sales.environment@metergroup.com

Phone: +1.509.332.5600

Fax: +1.509.332.5158

Website: metergroup.com

EUROPE

Customer service representatives are available for questions, problems, or feedback Monday through Friday, 8:00 to 17:00 Central European time.

Email: support.europe@metergroup.com
sales.europe@metergroup.com

Phone: +49 89 12 66 52 0

Fax: +49 89 12 66 52 20

Website: metergroup.com

SERVICE

If contacting METER by email, please include the following information:

Name	Email address
Address	Instrument serial number
Phone	Description of the problem

NOTE: For products purchased through a distributor, please contact the distributor directly for assistance.

4.4 TERMS AND CONDITIONS

By using METER instruments and documentation, you agree to abide by the METER Group, Inc. Terms and Conditions. Please refer to metergroup.com/terms-conditions for details.

INDEX

A

accuracy 7

C

cable length 8

calibration 10

compliance 8

connector types 8

customer support 11

E

email address 11

F

fax number 11

I

installation 2

P

phone number 11

R

range 7

rise time 3

S

specifications 7–8

 communication 7

 data logger compatibility 8

 measurement specifications 7

 physical 7

T

terms and conditions 12

METER Group Inc.

2365 NE Hopkins Court Pullman, WA 99163
T: +1.509.332.2756 F: +1.509.332.5158
E: info@metergroup.com W: metergroup.com

METER Group GmbH

Mettlacher Straße 8, 81379 München
T: +49 89 1266520 F: +49 89 12665220
E: info.europe@metergroup.com W: metergroup.com

