

TABLE OF CONTENTS

1. Introduction	1
2. Operation	2
2.1 Installation	2
2.2 Connecting.....	5
2.2.1 Connect to METER Logger	5
2.2.2 Connect to Non-METER Logger	6
2.3 Communication	8
2.3.1 SDI-12.....	8
3. System	9
3.1 Specifications.....	9
3.2 Solar Radiation (Pyranometer).....	12
3.3 Barometric Pressure	13
3.4 Tilt Sensor.....	13
3.5 GPS Sensor	14
3.6 Sensor Description and Process	14
3.7 Theory	16
3.8 Sensor Measurement Timing	19
3.9 Limitations	21
4. Service	23
4.1 Calibration	23
4.2 Recalibration Recommendations.....	24
4.3 Cleaning and Maintenance.....	24
4.4 Update Firmware	26

4.5 Troubleshooting.....	27
4.6 Error Sensor Diagnostics	27
4.7 Customer Support.....	29
4.8 Terms and Conditions	29
References	30
APPENDIX A. Compliance Certifications.....	31
A.1 USA.....	31
A.2 European Union	32
Index	33



INDEX



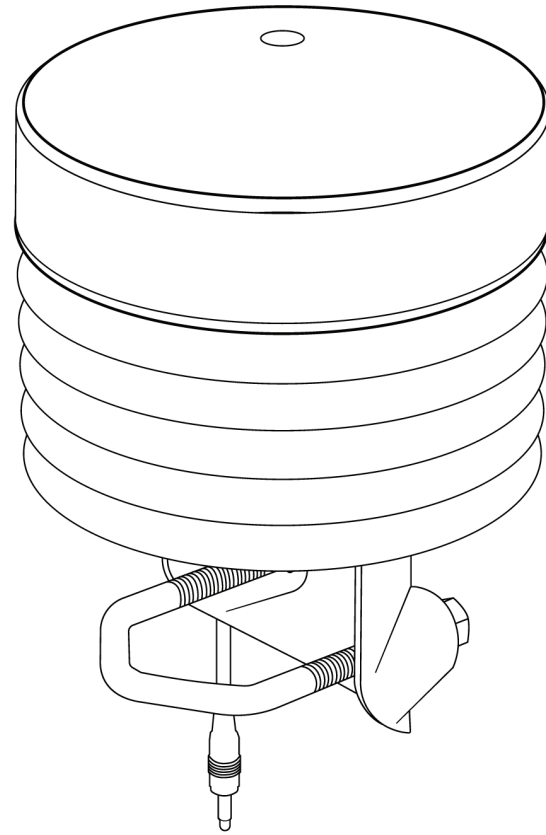

INDEX

C

calibration
 frequency **24**
 initial **23–24**
 cleaning **24–26**
 compliance
 CE **32**
 FCC **31**
 IC **31–32**
 connecting **5–7**
 customer support **28–29**

D

data acquisition system **10**. *See also* installation, connecting the ATMOS 51

E

email address **28, 29**

F

fax number **28, 29**

I

installation
 tools required **2**

M

maintenance **24–26**
 measurements
 air temperature **23**
 barometric pressure **23**
 lightning distance **24**
 relative humidity **23**

solar radiation **9, 23**
 tilt **23**
 vapor pressure **9, 23**
 measurement specifications. *See* specifications, measurement specifications

P

phone number **28, 29**

R

references **30**

S

specifications
 cable length **10**
 communication **10**
 data logger compatibility **10**
 dimensions **10**
 physical **10**

T

terms and conditions **29**
 troubleshooting **27–29**

APPENDIX A

8595A-LISAU201 or 8595A-LISAU200N (EM60G only)

Radio Frequency (RF) Exposure Information

This device has been evaluated and shown compliant with the IC RF Exposure limits under mobile exposure conditions (antennas are greater than 20cm from a person's body).

Avis d'Industrie Canada (IC)

Cet appareil numérique de classe B est conforme aux normes canadiennes CAN ICES-3(B) / NMB- 3(B) et RSS-210.

Son fonctionnement est soumis aux deux conditions suivantes:

- cet appareil ne doit pas causer d'interférence
- cet appareil doit accepter toute interférence, notamment les interférences qui peuvent affecter son fonctionnement

Informations concernant l'exposition aux fréquences radio (RF)

Ce périphérique a été évalué et démontré conforme aux limites d'exposition aux fréquences radio (RF) d'IC lorsqu'il est installé dans des produits hôtes particuliers qui fonctionnent dans des conditions d'exposition à des appareils mobiles (les antennes se situent à plus de 20 centimètres du corps d'une personne).

Changes or modifications to the EM60 series loggers not expressly approved by METER Group, Inc. could void Industry Canada (IC) compliance and thus the user's authority to operate the equipment.

A.2 EUROPEAN UNION

R&TTED and European Conformance CE mark

Radiofrequency radiation exposure Information: this equipment complies with radiation exposure limits prescribed for an uncontrolled environment for fixed and mobile use conditions. This equipment should be installed and operated with a minimum distance of 20 cm between the radiator and the body of the user or nearby persons. This transmitter must not be co-located or operating in conjunction with any other antenna or transmitter except as authorized in the certification of the product.

A full CE declaration of conformity for the EM60 is available on request from METER Group.

1. INTRODUCTION

Thank you for choosing the ATMOS 51 Variance Bowen Ratio (VBR) Evapotranspiration Sensor from METER Group.

The ATMOS 51 VBR ET Sensor is designed for monitoring the environmental variables that determine evapotranspiration rate. It computes and outputs the rate of evapotranspiration for a crop. The latent heat flux is measured (Eq. 3, see [Section 3.7](#) for equations), and it is divided by the latent heat of evaporation to calculate the evapotranspiration.

The ATMOS 51 VBR makes the following measurements:

- Solar radiation
- Air temperature
- Barometric pressure
- Vapor pressure
- Specific humidity
- GPS location and time
- Tilt

All sensors are integrated into a single, small form-factor unit, requiring minimal installation effort. For most applications no other sensors are needed to measure evaporation rate. Additional advantages include its low-power design that supports battery-operated data loggers with an SDI-12 three-wire interface. A tilt sensor warns the user of an out-of-level condition, and no configuration is necessary.

2. OPERATION

Please read all instructions before operating the ATMOS 51 to ensure it performs to its full potential.

⚠ PRECAUTION

METER sensors are built to the highest standards, but misuse, improper protection, or improper installation may damage the sensor and possibly void the manufacturer's warranty. Before integrating ATMOS 51 into a system, make sure to follow the recommended installation instructions and have the proper protections in place to safeguard sensors from damage.

2.1 INSTALLATION

Follow the steps listed in [Table 1](#) to set up the ATMOS 51 VBR Sensor and start collecting data.

Table 1 Installation

Tools Needed	<p>Wrench 13 mm (1/2 in)</p> <p>Mounting pole 31.8 to 50.8 mm (1.25 to 2.0 in) diameter, long enough to mount the Instrument 1.5 to 2 meters above the top of the vegetation.</p> <p>NOTE: Smaller mounts are compatible if washers are added to the V-bolt (not included). United States standard pipe sizes that are compatible are 1.00-, 1.25-, and 1.50-in. Square tubing with a width of 1.25 to 2.00 in or T-posts can also work as mounting options.</p>
Preparation	<p>Identify Mounting Location—Landscape</p> <p>The ATMOS 51 VBR ET Sensor measures the turbulent transport of water vapor in the atmosphere above a crop or soil surface. The thickness of the boundary layer through which that transport occurs depends on the upwind distance to the edge of the field that is being monitored. The surface boundary layer is equilibrated with a new surface to a height of around a fiftieth to a hundredth of the upwind distance to the field's windward edge. Ideally the ATMOS 51 VBR ET Sensor would be mounted at a height of 1.5 to 2 m above the top of the vegetation and 150 to 200 m from any edge. If this isn't possible, determine the direction of prevailing wind and make sure that direction has at least 150 to 200 m of fetch. The sensor measures the evaporation from the area within the 150 to 200 m radius of the sensor. Since the sensor measures solar radiation, the Installation site should have an unobstructed view of the sky above the sensor for all sun angles.</p> <p>Turbulent transport theory generally assumes large, flat exchange surfaces. Turbulent transport, of course, also occurs on steep mountainsides and urban sprawl, but the theory and practice are harder to connect. Gradually sloping fields should pose no problem, but steeper slopes and surrounding obstructions might. The ATMOS 51 VBR ET Sensor will give a plausible reading in all these cases, but the user will need to make a judgment on the reliability of the reading, since the theory doesn't provide guidance for those situations.</p>

APPENDIX A. COMPLIANCE CERTIFICATIONS

This appendix contains compliance statements that apply to the EM60 and EM60G.

A.1 USA

The following FCC statement applies to the EM60 and EM60G. This device complies with Part 15 of the FCC Rules. Operation is subject to the following conditions:

1. This device may not cause harmful interference.
2. This device must accept any interference received, including interference that may cause undesired operation.

The EM60 series loggers contain one or more of the following radio modules, listed by their FCC identification numbers:

- SH6MDBT40 (all EM60 series)
- XPYLISAU201 or XPYLISAU200 (EM60G only)

Changes or modifications to the EM60 series loggers not expressly approved by METER Group, Inc. could void FCC compliance and thus the user's authority to operate the equipment.

This equipment has been tested and found to comply with the limits for a Class B digital device, pursuant to Part 15 of the FCC Rules. These limits are designed to provide reasonable protection against harmful interference in a residential installation. This equipment generates, uses, and can radiate radio frequency energy and, if not installed and used in accordance with the instructions, may cause harmful interference to radio communications.

There is no guarantee that a particular installation will not cause any interference. If this equipment does cause harmful interference to radio or television reception, which can be determined by turning the equipment off and on, METER encourage users to attempt to correct the interference by trying one or more of the following measures:

- Reorient or relocate the receiving antenna
- Increase the separation between the equipment and receiver
- Consult [Customer Support](#)

Industry Canada (IC) Notices

This Class B digital apparatus complies with Canadian CAN ICES-3(B) / NMB-3(B) and RSS-210. Operation is subject to the following two conditions:

- this device may not cause interference
- this device must accept any interference, including interference that may cause undesired operation of the device

The EM60 series loggers contain one or more of the following radio modules, listed by their IC identification numbers:

- 8017A-MDBT40 (all EM60 series)

REFERENCES

- Buck, Arden L. 1981. New Equations for Computing Vapor Pressure and Enhancement Factor. *Journal of Applied Meteorology*. 20 (12):1527–1432.
- Campbell, Gaylon S. and Michael H. Unsworth. 1979. An Inexpensive Sonic Anemometer for Eddy Correlation. *Journal of Applied Meteorology*. 18 (8):1072–1077.
- Robinson, R.A. and Stokes, R.H. 1970. *Electrolyte Solutions*. 2nd ed. New York: Dover Publications.

Table 1 Installation (continued)

<p>Preparation (cont.)</p>	<p>Conduct Systems Check Plug the sensor into the logger (Section 2.2).</p> <p>Verify all sensors are functional and read within expected ranges. Remember that the fast specific humidity is auto-calibrated by exposing it outdoors for a day or two, do not expect it to be correct initially.</p> <p>Install Mounting Pole Use a mounting pole with a 31.8- to 50.8-mm (1.25- to 2.0-in) diameter.</p> <p>Prepare the mounting pole to the appropriate height. The sensor should be 1.5 to 2 m above the top of the vegetation. As the crop grows the sensor height can be increased, or the sensor can just be mounted 1.5 to 2 m above the eventual maximum crop height.</p> <p>The mounting pole should be within 4.5° of perpendicular to allow for leveling using the built-in level adjustment.</p>
<p>Field Installation</p>	<p>Conduct System Check Plug the ATMOS 51 into the logger (Section 2.2).</p> <p>Verify all sensors are functional and read within expected ranges.</p> <p>Mount and Secure Device Use a mounting pole with a 31.8- to 50.8-mm (1.25- to 2.0-in) diameter.</p> <p>Prepare the mounting pole to the appropriate height. The mounting pole should be within 4.5° of level.</p> <p>Tighten the V-bolt nuts by hand until hand-tight. Then tighten the nuts further with the 13-mm end of the wrench included. Secure the ATMOS 51 flat and tight against the top of the mounting pole.</p> <p>⚠ CAUTION Do not overtighten the clamp.</p>

OPERATION

Table 1 Installation (continued)

Field Installation

Level the Device

The ATMOS 51 VBR ET Sensor level can be adjusted by (1) loosening the leveling screw attached to the bottom with the 8-mm end of the wrench (included), (2) moving the ATMOS 51 VBR ET Sensor side to side as needed to level, and then retightening the screw. Use the bubble level and ZENTRA Utility Sensor Leveling tool to ensure the sensor is level during the sensor installation.

The ATMOS 51 VBR ET Sensor must be within approximately $\pm 1^\circ$ of dead level to accurately measure solar radiation.

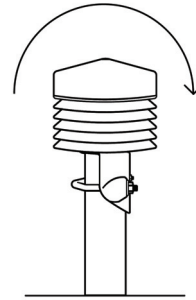

Secure and Protect Cables

Install cables in conduit or plastic cladding when near the ground to avoid rodent damage.

Gather and secure cables between the ATMOS 51 and the data logger to the mounting mast in one or more places.

NOTE: Improperly protected cables can lead to severed cables or disconnected sensors. Cabling issues can be caused by many factors such as rodent damage, driving over sensor cables, tripping over cables, not leaving enough cable slack during installation, or poor sensor wiring connections.

Secure and Protect Cables

Plug the sensor into a data logger.

Use the data logger to make sure the sensor is reading properly. Verify that the readings are within expected ranges.

For more instructions on connecting to data loggers, refer to [Section 2.2](#).

NOTE: ATMOS 51 VBR will not work with legacy METER Group data loggers (Em50 Series and Em5B).

ATMOS 51

4.7 CUSTOMER SUPPORT

NORTH AMERICA

Customer service representatives are available for questions, problems, or feedback Monday through Friday, 7:00 am to 5:00 pm Pacific time.

Email: support.environment@metergroup.com
sales.environment@metergroup.com

Phone: +1.509.332.5600

Fax: +1.509.332.5158

Website: metergroup.com

EUROPE

Customer service representatives are available for questions, problems, or feedback Monday through Friday, 8:00 to 17:00 Central European time.

Email: support.europe@metergroup.com
sales.europe@metergroup.com

Phone: +49 89 12 66 52 0

Fax: +49 89 12 66 52 20

Website: metergroup.com

If contacting METER by email, please include the following information:

Name	Email address
Address	Instrument serial number
Phone	Description of the problem

NOTE: For products purchased through a distributor, please contact the distributor directly for assistance.

4.8 TERMS AND CONDITIONS

By using METER instruments and documentation, you agree to abide by the METER Group, Terms and Conditions. Please refer to metergroup.com/terms-conditions for details.

SERVICE

Table 5 Sensor Diagnostic Codes (continued)

100's	Fast Temp and Humidity	<p>0XX Fast T and RH good</p> <p>1XX Fast T nonfunctional</p> <p>2XX Fast RH nonfunctional</p> <p>3XX Fast T and RH nonfunctional</p>	<p>1:3 Uses slow T and/or RH for variance calculations</p>
1000's	Pyranometer	<p>0XXX Pyranometer in calibration</p> <p>1XXX Pyranometer needs calibration</p> <p>2XXX Pyranometer failed</p>	<p>1 Degraded operation</p> <p>2 No ET prediction</p>
10000's	GPS	<p>0XXXX GPS working normally</p> <p>1XXXX GPS not functional</p>	<p>Backup net radiation calculation</p> <p>No pyranometer autocalibration</p>

An example of how to use these diagnostic codes in Table 5 to troubleshoot may look like this:

A diagnostic code of 21 suggests that the instrument is 2 to 4 degrees off level and that the variance Bowen ratio is higher than 2. These flags suggest that uncertainty in the ET measurements is possible if the radiation estimates are incorrect, given the instrument position. Likewise, a diagnostic code of 11020 would indicate that the GPS is not functional, the pyranometer needs a calibration, and the instrument is 2 to 4 degrees off level. This flag indicates that the instrument likely needs servicing or that the data should be used with caution.

ATMOS 51

2.2 CONNECTING

The ATMOS 51 works seamlessly with the METER ZL6 data logger. The ATMOS 51 can also be used with other data loggers, such as those from Campbell Scientific, Inc. using SDI-12 communication.

ATMOS 51s using SDI-12 communication require an excitation voltage in the range of 3.9 to 15.0-VDC and operates at a 2.8- to 5.5-VDC level for data communication. The ATMOS 51 can be integrated using SDI-12 protocol.

ATMOS 51 sensors come with a 3.5-mm stereo plug extension connector (Figure 1) to facilitate easy connection with METER loggers. ATMOS 51 sensors may be ordered with stripped and tinned wires to facilitate connecting to some third-party loggers (Section 2.2.2).

For detailed directions on how to integrate the sensor into third-party loggers, refer to the [ATMOS 51 Integrator Guide](#) to integrate into SDI-12 systems.

A 1.5-m M12 connector that attaches to a standard 5m cable may be purchased with custom cable lengths for an additional fee (on a per-meter basis). In some instances, the cable can be extended beyond 75 m by the user, but this is discouraged for a variety of reasons. Please contact [Customer Support](#) for more details before extending or splicing cables.

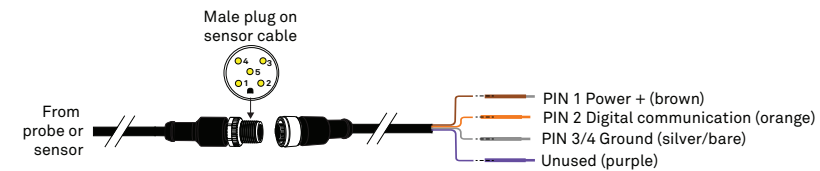

Figure 1 M12 connector wiring

2.2.1 CONNECT TO METER LOGGER

The ATMOS 51 works most efficiently with ZENTRA series data loggers. Check the METER downloads webpage (metergroup.com/support/downloads-page) for the most recent data logger firmware. Logger configuration may be done using either ZENTRA Utility (desktop and mobile application) or ZENTRA Cloud (web-based application for cell-enabled data loggers).

NOTE: This system will not work with legacy data loggers (Decagon Em5, Em5B, Em50, Em50R, and Em50G).

1. Screw the M12 connector coming from the ATMOS 51 into the M12 connector end of the stereo plug extension. Plug the stereo connector into the logger.
2. Use the appropriate software application to configure the chosen logger port for the ATMOS 51. METER data loggers will automatically recognize ATMOS 51 sensors.
3. Set the measurement interval.

METER data loggers measure the ATMOS 51 every minute and return the average of the 1-min data across the chosen measurement interval.

OPERATION

NOTE: The ATMOS 51 draws more current than other METER sensors because it makes frequent measurements. As a result, plugging multiple ATMOS 51 sensors into a single ZENTRA or EM60 data logger may have an impact on battery life. At times or in regions with plentiful sunshine, the solar panel should provide ample charge and this should not be an issue. During the winter or periods of extended heavy clouds, the solar panel may not provide enough charging current to keep the system running with multiple ATMOS 51 units. METER recommends using two or fewer ATMOS 51 per ZL6 or EM60 data logger.

ATMOS 51 data can be downloaded from METER data loggers using either ZENTRA Utility or ZENTRA Cloud. Refer to the logger user manual for more information about these programs.

2.2.2 CONNECT TO NON-METER LOGGER

The ATMOS 51 can be purchased for use with non-METER (third party) data loggers. Refer to the third-party logger manual for details on logger communications, power supply, and ground ports. The [ATMOS 51 Integrator Guide](#) also provides detailed instructions on connecting sensors to non-METER loggers. **For the ATMOS 51 to work properly it must be continuously excited.**

ATMOS 51 sensors can be ordered with stripped and tinned (pigtail) wires for use with screw terminals. Refer to the third-party logger manual for details on wiring.

Connect the ATMOS 51 wires to the data logger as illustrated in [Figure 2](#) and [Figure 3](#), with the power supply wire (brown) connected to the excitation, the digital out wire (orange) to a digital input, and the bare ground wire to ground. The power to the ATMOS 51 VBR ET Sensor needs to be continuous. When power is first applied the GPS will try to get a fix. Current consumption during that time (several minutes, depending on the location of satellites) will be around 10 mA. Once the ATMOS 51 VBR ET Sensor gets a fix, power consumption will drop to around 30 microamps. The ATMOS 51 VBR ET Sensor is continuously sampling, computing, and accumulating the data needed to get the net radiation and Bowen ratio, so power shouldn't be interrupted.

Connect the ATMOS 51 wires to the data logger as illustrated in [Figure 2](#) and [Figure 3](#), with the power supply wire (brown) connected to the excitation, the digital out wire (orange) to a digital input, and the bare ground wire to ground. The purple wire is not used for communication.

NOTE: METER pigtail extensions come with an additional purple wire. This wire is not for SDI communication and should be ignored.

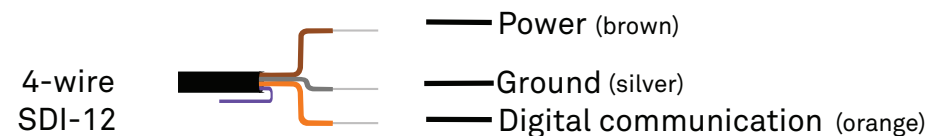

Figure 2 Pigtail wiring

ATMOS 51

4.5 TROUBLESHOOTING

Table 4 Troubleshooting the ATMOS 51

Problem	Possible Solutions
ATMOS 51 not responding	Check power to the sensor.
	Check sensor cable and stereo plug connector integrity.
	Try a different port on the data logger.
	For SDI-12 version check data logger wiring to ensure the following connections: Brown—3.6- to 15.0-V power supply Orange—digital out Bare—ground
	NOTE: If none of these solutions work contact Customer Support for more information

4.6 ERROR SENSOR DIAGNOSTICS

The ATMOS 51 generates diagnostic error codes to help identify anomalies in the data and assist with the QA/QC of data outputs. These codes are generated for each measurement interval, allowing direct ways to ensure data quality and that the instrument is functioning properly.

Table 5 Sensor Diagnostic Codes

Digit	Sensor	Code and Meaning	Consequence for value >0
1's	Bowen Ratio	0 Bowen ratio < = 2	1 Likely dry, sparse vegetation. R_n and G estimates may be incorrect ET may be overestimated
		1 Bowen ratio > 2	
10's	Level	0X Level within 1°	1 Poor radiation measurements 2 Degraded operation 3 No ET prediction
		1X 1° to 2° off level	
		2X 2° to 4° off level	
		3X More than 4° off level; not usable	

SERVICE

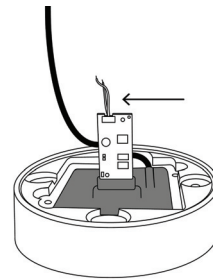

Figure 10 Temporary sensor board

Here is a close-up of the sensor board (Figure 10) with the fine thermocouple sticking out the top. If changing sensor boards, just unplug the old one and plug in the new one, again, being very careful of the thermocouple wires.

If the thermocouple needs straightening, do so **carefully** with forceps applying a minimum of strain to the wires. The thermocouple needs to protrude through the hole in the bottom of the screen shield.

7. Once the sensor board is replaced, replace the screen shield. Make sure the thermocouple sticks out the bottom.
8. Replace the top on the radiation shield, **use care to assure the thermocouple isn't bent or damaged.**
9. Finally replace the long screws and the leveling mount.

4.4 UPDATE FIRMWARE

METER will occasionally release firmware updates that improve ATMOS 51 performance. Please consult with [Customer Support](#) about the necessity or process of updating firmware on ATMOS 51.

ATMOS 51

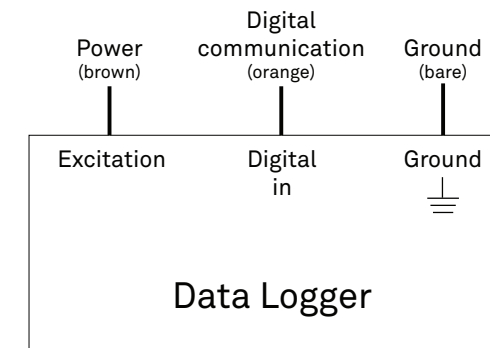

Figure 3 Three-wire SDI-12 wiring diagram

NOTE: The acceptable range of excitation voltages is from 3.6 to 15.0 VDC. To read the ATMOS 51 with Campbell Scientific data loggers, power the sensors from a continuous 12-V port.

If the ATMOS 51 cable has a standard stereo plug connector and needs to be connected to a non-METER data logger, use one of the following two options.

Option 1

1. Clip off the stereo plug connector on the sensor cable.
2. Strip and tin the wires.
3. Wire it directly into the data logger.

This option has the advantage of creating a direct connection and minimizing the chance of the sensor becoming unplugged. However, it cannot be easily used in the future with a METER readout unit or data logger.

Option 2

Obtain an adapter cable from METER.

The adapter cable has a connector for the M12 connector on one end and three wires (or pigtail adapter) for connection to a data logger on the other end. The stripped and tinned adapter cable wires have the same termination as in Figure 3: the brown wire is excitation, the orange is output, and the bare wire is ground. The purple wire is not for SDI communication and should be ignored.

NOTE: Secure the stereo plug connector to the pigtail adapter connections using adhesive-lined heat shrink to ensure the sensor does not become disconnected during use.

2.3 COMMUNICATION

The ATMOS 51 can communicate using SDI-12.

2.3.1 SDI-12

The SDI-12 protocol requires that all sensors have a unique address. ATMOS 51 sensor factory default is an SDI-12 address of 0. To add more than one SDI-12 sensor to a bus, the sensor address can be changed using a ZSC Bluetooth® sensor interface and the ZENTRA Utility Mobile app as described below:

NOTE: The sensor SDI-12 address must be returned to 0 to work with ZENTRA loggers.

1. Using a mobile device, open the ZENTRA Utility Mobile app.
2. Connect the sensor to the ZSC.
3. Under **Sensor Information**, select the SDI Address dropdown.
4. Scroll through the options and select the desired SDI-12 address.

NOTE: Address options include 0-9, A-Z, and a-z.

Detailed information can also be found in the application note [Setting SDI-12 addresses on METER digital sensors using Campbell Scientific data loggers and LoggerNet](#) (meter.ly/article-SDI-12-use-Campbell).

When using the sensor as part of an SDI-12 bus, excite the sensors continuously.

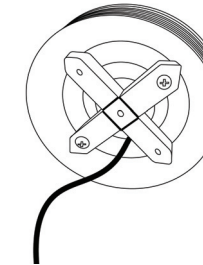

Figure 8 Detached mounting base

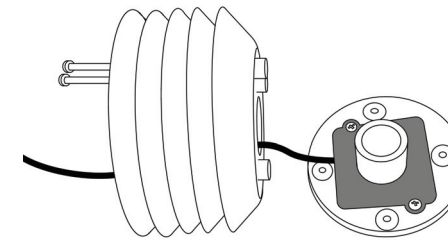

Figure 9 Screws in plate

2. Remove the two #10-32 long screws that hold the top plate in place.
3. With the screws removed the top plate can be removed.
4. Set it on a soft cloth or cover the pyranometer diffuser with a protective cover so it will not get abraded or scratched.

The cable can be fed through the radiation shield. Note the screen shield around the sensor board and the fine thermocouple sticking out the bottom of the shield.



The thermocouple is made from 0.003 in. or .075 mm. wires (see [Figure 10](#)). It is very fragile. Do not touch or bend it.

5. Remove the two screws holding the screen shield in place, and carefully pry the shield away from the top assembly.
6. Lift off the screen shield, again taking care not to bend or break the thermocouple. Gently clean with water and or compressed air to remove debris.

4.2 RECALIBRATION RECOMMENDATIONS

Table 3 lists the recommended sensor calibration frequencies.

Table 3 Sensor calibration frequencies

Sensor Function	Measurement Drift	Calibration Frequency
Solar radiation	<2% drift/year	Every 2 years ^a
Barometric pressure	0.1 kPa/year (typical)	Every 1–2 years
Relative humidity	<0.25% RH/year	Every 2 years
All other sensors		Not needed

^a ATMOS 51 barometric pressure, temperature, and humidity sensors and their respective calibrations are housed on a replaceable board (see Figure 10) inside the radiation shield. This board is field-swappable, so sensors in need of calibration can be removed and replaced by a board with calibrated sensors. Please contact [Customer Support](#) for new sensor boards.

4.3 CLEANING AND MAINTENANCE

This section covers cleaning and maintaining the ATMOS 51. For more information on thoroughly cleaning the ATMOS 51, see [ATMOS cleaning instructions](#) (meter.ly/atmoscleaning).

CAUTIONS BEFORE BEGINNING

- **DO NOT** immerse the ATMOS 51 in water.
- **DO NOT** touch the fast temperature sensor thermocouple.

NOTE: The fast temperature sensor thermocouple wires are very delicate and can be easily damaged.

1. Make sure nothing is obscuring the temp. sensors or the humidity sensors (cobwebs, wasp nests, insects, etc.) Use a soft cloth to remove obscuring objects.
2. Check the screen shield and radiation shield are clear of miscellaneous environmental, animal (specifically bird droppings), and other debris.
3. Make sure the ATMOS 51 is level after cleaning with the bubble mounting base.

MAINTAINING/REPLACING THE SENSOR BOARD

1. Remove the 8 mm leveling screw and detach the mounting base (Figure 8).

3. SYSTEM

This section describes the specifications and theory of the ATMOS 51 Variance Bowen Ratio sensor.

3.1 SPECIFICATIONS

MEASUREMENT SPECIFICATIONS

Solar Radiation	
Range	0–1750 W/m ²
Resolution	1 W/m ²
Accuracy	±5% of measurement typical
Relative Humidity	
Range	0–100% RH (0.00–1.00)
Resolution	0.01% RH
Accuracy	1% RH, typical
Long-Term Drift	±0.25% RH/year, typical
Air Temperature Sensor	
Range	–40 to 60 °C
Resolution	0.01 °C
Accuracy	±0.1 °C
Barometric Pressure	
Range	26–126 kPa
Resolution	0.01 kPa
Accuracy	±0.003 kPa at 25 °C
Equilibration	< 10 ms
Long-Term Drift	< 0.03 kPa/year, typical
Tilt	
Range	0° to 180°
Resolution	0.1°
Accuracy	0°, -10°, ±1°, 10°–180°, ±10% of reading

COMMUNICATION SPECIFICATIONS**Output**

SDI-12 communication

Data Logger Compatibility

METER ZL6 and EM60 data loggers or any data acquisition systems capable of 3.6- to 15.0-VDC excitation and SDI-12 communication

PHYSICAL CHARACTERISTICS**Dimensions**

Diameter 14 cm (5.5 in)

Height 21 cm (8.2 in)

Operating Temperature Range

Minimum -40 °C

Typical NA

Maximum 60 °C

NOTE: Barometric pressure and relative humidity sensors operate accurately at a minimum of -40 °C.**Cable Length**

5 m (standard)

75 m (maximum custom cable length for additional cost)

NOTE: Contact [Customer Support](#) if a nonstandard cable length is needed.**Connector Types**

Stereo plug connector or 3 stripped and tinned wires

Plug Connector Diameters

Stereo Plug with 4.2 ±0.2 mm (0.16 ±0.01 in), minimum jacket of 0.8mm (0.031 in)

M12 Plug with 5.5 ±0.2 mm (0.22 ±0.01 in), minimum jacket of 1.0 mm (0.039 in)

Conductor Gauge

22-AWG / 24-AWG drain wire

Cable Diameter

0.165 ±0.004 in (4.20 ±0.10 mm), with minimum jacket of 0.030 in (0.76 mm)

4. SERVICE

This section contains calibration and recalibration information, calibration frequencies, cleaning and maintenance guidelines, troubleshooting guidelines, customer support contact information, and terms and conditions.

4.1 CALIBRATION

• **Solar Radiation:** ATMOS 51 pyranometers are calibrated through side-by-side comparison to the mean of four Apogee model SP-110 transfer standard pyranometers (shortwave radiation reference) under high-intensity discharge metal halide lamps. The transfer standard pyranometers are calibrated through side-by-side comparison to the mean of at least two ISO-classified reference pyranometers under sunlight (clear sky conditions) in Logan, Utah. Each of four ISO-classified reference pyranometers are recalibrated on an alternating yearly schedule (two instruments each year) at the National Renewable Energy Laboratory (NREL) in Golden, Colorado. NREL reference standards are calibrated to the World Radiometric Reference (WRR) in Davos, Switzerland

METER recommends using the model from the Clear Sky Calculator, developed by Apogee Instruments, to determine uncertainty of the pyranometer on the ATMOS 51. The calculator is available on clearskycalculator.com or in the respective app store for a mobile device. Should the uncertainty be higher than 5% (or other preferred number) the unit should be replaced with a new pyranometer. Contact [Customer Support](#) if a new pyranometer is needed.

A custom pyranometer calibration factor can be calculated using the Clear Sky Calculator. Neither Apogee Instruments nor METER guarantee this method is as accurate as a new unit that has recently been calibrated, but, if done properly, it should result in better than 5% accuracy in the solar radiation measurements.

- **Air Temperature:** The air temperature sensor is specified to be accurate to 0.1 °C by the original manufacturer. All sensors are verified against a NIST-traceable standard thermometer at the time of manufacture.
- **Barometric Pressure:** Each ATMOS 51 barometric pressure sensor is calibrated against the average of three secondary standard Measurement Specialties MS5611 pressure sensors. The MS5611 sensors are calibrated every 3 months against a GE Druck TERPS 8100-series pressure sensor. The GE pressure sensor is calibrated yearly at certified laboratory with NIST traceability.
- **Sensor Tilt:** The ATMOS 51 tilt sensor is zeroed against the primary bubble level on the mounting base.

SYSTEM

These conditions are most likely to be observed during nights or periods rapidly cooling air temperatures. Hence, it is suggested to install ATMOS 51 VBR ET Sensor on flat terrain or areas that will not be influenced by advective gradients.

Nighttime Fluxes

Most of the water exchange occurs during the day with high-radiation and increasing temperature gradients. Nighttime transpiration and evaporation can occur in arid ecosystems, periods of warming nights, and nights that do not cool below dewpoint. The ATMOS 51 VBR ET Sensor does not account for nighttime water losses as the instrument relies on the incoming radiation to calculate evapotranspiration.

ATMOS 51

ELECTRICAL AND TIMING CHARACTERISTICS

Supply Voltage (VCC to GND)

Minimum	3.9 VDC continuous
Typical	NA
Maximum	15.0 VDC continuous

NOTE: ATMOS 51 must be continuously powered to work properly.

NOTE: For the ATMOS 51 to meet digital logic levels specified by SDI-12, it must be excited at 3.9 VDC or greater.

Digital Input Voltage (logic high)

Minimum	2.8 V
Typical	3.0 V
Maximum	5.5 V

Digital Input Voltage (logic low)

Minimum	-0.3 V
Typical	0.0 V
Maximum	0.8 V

Digital Output Voltage (logic high)

Minimum	NA
Typical	3.6 V
Maximum	NA

NOTE: For the ATMOS 51 to meet digital logic levels specified by SDI-12, it must be excited at 3.9 VDC or greater.

Current Drain (during GPS fix)

Minimum	5.0 mA
Typical	8.0 mA
Maximum	10.0 mA

Current Drain (during measurement, 75 ms/s)

Minimum	0.2 mA
Typical	1.0 mA
Maximum	2.0 mA

SYSTEM

Current Drain (while asleep, 925 ms/s)	
Minimum	0.02 mA
Typical	0.03 mA
Maximum	0.04 mA
Measurement Duration	
Minimum	NA
Typical	75 ms
Maximum	100 ms

COMPLIANCE

EM ISO/IEC 17050:2010 (CE Mark) 

3.2 SOLAR RADIATION (PYRANOMETER)

Solar radiation is measured by a pyranometer that is integrated into the cap of the ATMOS 51. Designed, manufactured, and calibrated by experts at Apogee Instruments, the miniature pyranometer uses a silicon-cell sensor to measure the total incoming (direct and diffuse) solar radiation. A carefully developed cosine-correcting head ensures accurate readings regardless of sun angle, while the painstakingly researched optical filter material balances cost and performance to ensure the silicon-cell provides good accuracy regardless of temperature or sensor age. Silicon-cell sensors have excellent response time to changing radiation conditions and acceptable sensitivity across the solar spectrum (Figure 4), which makes them perfect for use in the ATMOS 51.

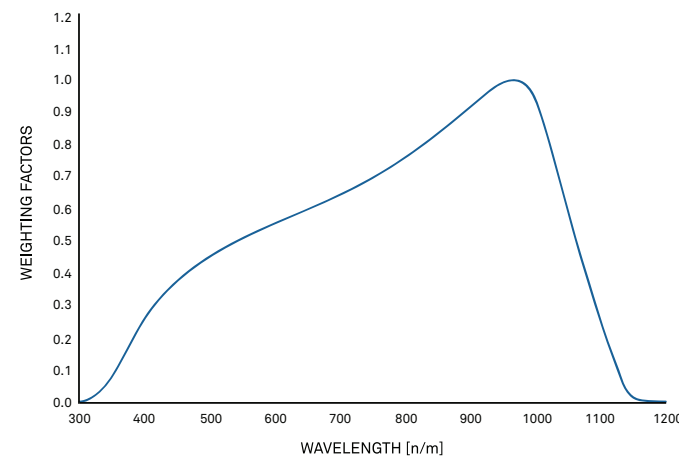

Figure 4 Spectral response estimate of Apogee silicon-cell pyranometers

ATMOS 51

3.9 LIMITATIONS

The ATMOS 51 is engineered to be a robust device with minimal downtime. However, it does have limitations that will affect its measurements under some conditions.

Heavy Rain and Strong Wind

Strong winds accompanied by rain can carry water inside the radiation shield. This shouldn't damage sensors as long as the water is rainwater with no salt. Water from sprinklers getting on the sensors will damage them. Sensors will be off-line until they dry out.

Non-evaporating or Transpiring Conditions

The theory of the Bowen Ratio Energy Balance relies on the assumption that turbulent wind simultaneously drives the vertical exchange of water and heat. Thus, the ATMOS 51 does not accurately capture the ratio of temperature and water exchange if sensor is placed over tracts with non-evapotranspiring or minimal evapotranspiring conditions. For example, parking lots experience high sensible heat fluxes and low, if not zero, latent heat resulting in disproportionate Bowen ratios, e.g., β greater than 2. These conditions may produce unrealistic flux estimates and are consequently flagged as suspect data.

Solar Radiometer Sensor Contamination

The ATMOS 51 VBR ET Sensor uses incoming radiation to calculate and estimate the net radiation that is partitioned into sensible and latent energy fluxes. The pyranometer installed on top the ATMOS 51 VBR ET Sensor must be clean and free of any contamination to generate accurate measurements. The sensor is designed to minimize contamination from dust but cleaning the sensor should be conducted as part of instrument maintenance. However, bird poop, dust, and other environmental contaminants are common and poor radiation estimates will alter estimates of latent energy and evapotranspiration.

Advection Issues

Advection is a process that drives the horizontal flow of water or heat, and these conditions are expected in all ecosystems. However, the Bowen ratio energy balance approach assumes an equal relationship between the vertical transport of water and heat. Thus, the presence of high advection limits the applicability of the Bowen ratio approach. Environmental factors and installation considerations can influence probability of advective fluxes. For example, tracts known to experience very high wind speeds will likely have more advective conditions as the high wind velocities reduce turbulent flow thus driving lateral water and temperature transport rather than the vertical gradients.

Detailed considerations of sensor placement during installation may help reduce advective conditions that can interfere with ATMOS 51 VBR ET Sensor measurements. Installing an ATMOS 51 VBR ET Sensor in valleys or at the bottom of slopes may increase advective temperature gradients as thermally dynamic air masses flow along topographical gradients.

SYSTEM

Table 2 ATMOS 51 output quantities on the METER and ZENTRA Loggers (continued)

Net Radiation	Average net radiation estimate W/m ²	Average of m 1-min averages of total net radiation	Basic (84) and Extended (83)
Air Temp.	Average air temp. (fast)	Average of m 1-min averages of air temp.	Basic (84) and Extended (83)
Specific Humidity	Average specific humidity g/kg (fast)	Average of m 1-min averages of specific humidity	Basic (84) and Extended (83)
Bowen Ratio	Average Bowen ratio (fast)	Average of m 1-min Bowen ratio averages	Basic (84) and Extended (83)
Tilt	Measurement of tilt	Average of instantaneous measurement of tilt	Basic (84) and Extended (83)
Diagnostic Codes	Integer error codes tracking measurement uncertainty	Error codes denoting measurement quality	Basic (84) and Extended (83)
Slow Temp.	Average air temp. (slow)	Average of m 1-min averages of air temp.	Extended (83)
Slow Specific Humidity	Average specific humidity (slow)	Average of m 1-min specific humidity measurements	Extended (83)
Slow Bowen Ratio	Average Bowen Ratio (slow)	Average of m 1-min Bowen ratio averages	Extended (83)
Slow σ Temp.	Standard deviation of air temp. (slow)	Standard deviation of m 1-min slow air temp.	Extended (83)
Fast σ Temp.	Standard deviation of air temp. (fast)	Standard deviation of m 1-min fast air temp.	Extended (83)
Slow σ Specific Humidity	Standard deviation of specific humidity (slow)	Standard Deviation of m 1-min slow specific humidity measurements	Extended (83)
Fast σ Specific Humidity	Standard deviation of specific humidity (fast)	Standard Deviation of m 1-min fast specific humidity measurements	Extended (83)
Minute of Day	Linear minute of day	Continuous count of minutes of the day	Extended (83)
Fast Covariances	Covariance of air temperature and specific humidity (fast)	Covariance for m 1-min fast specific humidity and fast temp. measurements	Extended (83)

ATMOS 51

The spectral range of solar radiation is 300 to 3000 nm. From [Figure 4](#) it is evident that the Apogee silicon cell pyranometer covers a much narrower range. However, for measurement of incoming solar radiation, the ratio of silicon cell measured solar radiation to that measured with a more expensive, full spectrum radiometer, is almost constant. A properly calibrated silicon cell therefore does a good job of measuring incoming solar radiation. It should not be used for reflected radiation or radiation under plant canopies where the spectral distribution of the radiation is drastically altered from that of Incoming solar radiation.

Leveling the ATMOS 51 is particularly important for accurate solar radiation measurements. Out of level, the pyranometer will overestimate some portions of the day while underestimating others. Ensure accurate solar radiation measurements by carefully leveling the ATMOS 51 at installation. Bird droppings and other soiling of the domed sensor surface will cause serious errors in pyranometer measurements. Check the sensor regularly to make sure it is clean and check data often to identify possible problems. Isopropyl (rubbing) alcohol and a Q-tip work well for cleaning the sensor area. Microfiber bags work well, too. Do NOT use an abrasive cloth on the sensor surface, as it will scratch. See [Section 4.3](#) for more information on sensor care and cleaning.

The pyranometer is factory calibrated and the sensor-specific calibration value. If the pyranometer is changed the calibration will need to be updated.

When powered on, the ATMOS 51 measures the solar radiation once every minute. When queried, the ATMOS 51 outputs the most recent 1-minute measurement of solar radiation.

3.3 BAROMETRIC PRESSURE

The barometric pressure sensor is located on the replaceable daughter board in the measurement chamber. It measures the atmospheric pressure of the environment in which the ATMOS 51 is deployed. With a range from 26 to 126 kPa, it is suitable for measurement across a wide range of elevations, but keep in mind that the magnitude of sensor output will depend chiefly on the installation altitude with subtle changes caused by weather. When powered on, the ATMOS 51 measures the barometric pressure once every second and computes an average value for use in computations.

3.4 TILT SENSOR

The ATMOS 51 is also equipped with a tilt sensor similar to those found in smartphones. The primary use of the tilt sensor data is to ensure the ATMOS 51 remains level at all times. Regularly check in ZUM and visually to ensure the ATMOS 51 is level; if it has tilted, return to the site and level again. Even a slightly off-level ATMOS 51 will cause errors in the solar radiation measurement.

When powered on, the ATMOS 51 measures the tilt once every 60 s and records the instantaneous value. When queried, the ATMOS 51 outputs the average of the instantaneous measurements since the last query.

3.5 GPS SENSOR

In order to determine net radiation, it is necessary to compute the net thermal radiation. The GPS sensor provides the clear sky solar radiation time and location information need to make the computation.

Integrated GPS sensor provides accurate location and time of the sensor. The location and time of day provide the necessary parameters to calculate the clear-sky solar radiation. The clear-sky radiation is used to estimate net thermal radiation which is required to determine the local net radiation.

3.6 SENSOR DESCRIPTION AND PROCESS

A labeled diagram of the ATMOS 51 VBR ET Sensor is shown in the following figure:

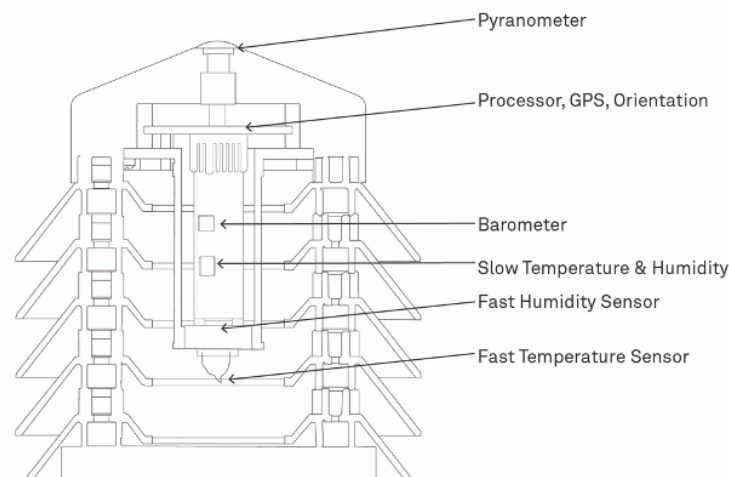

Figure 5 Cutaway view of ATMOS 51 Variance Bowen Ratio sensor

CAUTION: Thermocouple is fragile. Handle with care.

The Atmos 51 consists of the pyranometer sensor on top to measure the incident solar radiation and a 5-plate radiation shield which shields the sensors from solar radiation, and to some extent, from precipitation. The 5-plate radiation shield allows maximum wind movement past the sensors. The plates are mounted on a base plate that facilitates leveling, even when the sensor attaches to a pole that is not vertical. Inside the shield is:

- A level sensor that reports the orientation of the assembly
- GPS sensor that reports the geographical location and the time of day
- The barometric pressure sensor
- Two temperature sensors

To get the sign of the Bowen ratio, METER's patent pending technique simply repurposes the same measurements already made for the variance Bowen ratio calculation. Air temperature and specific humidity are sampled once per second, and compute the standard deviations for the variance Bowen ratio using Equation 5 and Equation 6. At the same time compute a covariance from:

$$Cov(T, q) = \sum(T - \bar{T})(q_i - \bar{q})$$

Equation 7

Where the overbar indicates an average of the values sampled every 10 s.

If above average specific humidities correspond to above average temperatures and below average specific humidities correspond to below average temperatures, then the sum will be positive. If above average specific humidities correspond to below average temperature and below average specific humidities correspond to above average temperature, the sum will be negative. This happens if there is a daytime inversion. If the covariance is negative, make the Bowen ratio negative.

3.8 SENSOR MEASUREMENT TIMING

METER EM60G and ZENTRA series data loggers query the ATMOS 51 once every minute and record the appropriate accumulations, averages, and maximums from the ATMOS 51 in memory. When the measurement interval is reached, the 1-min measurements are processed into the appropriate accumulations, averages, and maximums and output to final storage (see the logger manual for more information). Table 2 describes the quantities output from the ATMOS 51 and how they are processed in the logger for each ATMOS 51 measurement.

Table 2 ATMOS 51 output quantities on the METER and ZENTRA Loggers

Measurement	Data Output	Data Saved by Logger Intervals (m = minute)	Sensor Identity (Zentra Configuration)
Evaporation Rate	Average evaporation rate mm of water/hr.	Total mm of evaporation	Basic (84) and Extended (83)
Latent Heat	Average latent heat flux W/m ²	Averages of m 1-min latent heat flux	Basic (84) and Extended (83)
Solar Radiation	Average solar radiation W/m ²	Average of m 1- min incoming shortwave radiation	Basic (84) and Extended (83)

deviations of temperature and specific humidity are relatively easy to measure, and don't have the susceptibility to measurement error that two separate sensors have because all the measurements come from the same sensor and the offset and bias errors cancel out.

The standard deviations for temperature and specific humidity are calculated from:

$$\sigma_T = \sqrt{\frac{\sum(T_i - \bar{T})^2}{N}}$$

Equation 5

$$\sigma_q = \sqrt{\frac{\sum(q_i - \bar{q})^2}{N}}$$

Equation 6

Where N is the number of samples and the overbar indicates the average value over the sampling period.

Standard deviations are always positive, so the variance Bowen ratio, computed from the ratio of the standard deviations of temperature and specific humidity, is also positive. However, the values for H and λE , can be either positive or negative, depending on the direction of the heat or water vapor flux. The typical condition during the day, when net radiation is positive, is for both H and λE to be positive, and for the Bowen ratio to be positive, as the variance Bowen ratio always is. There could also be cases where both sensible and latent heat fluxes are negative, giving a positive Bowen ratio, but the interest is only in evaporation conditions, so negative latent heat flux conditions is not included. It is possible, however, to have a condition over a crop, where the latent heat flux is positive, but the sensible heat flux is negative. These are conditions are called "advective", and they occur when a well-watered, usually irrigated, crop is surrounded by dry, non-transpiring fields. The high vapor deficit of the air moving over the field causes heat to be extracted from the air to evaporate water, in addition to the heat from net radiation. This results in a daytime inversion over the crop, and the sensible heat flux being negative. In this case, the Bowen ratio is negative, but the variance Bowen ratio is still positive because of the way it is calculated.

- Two relative humidity sensors
- A microprocessor that reads the sensors and computes to determine evapotranspiration (See [Section 3.7](#)).

The first temperature and humidity sensor pair is carefully calibrated to laboratory standards, and serves as the reference sensors for the ATMOS 51. The response time of these reference sensors are too slow to measure the variances of many of the eddies that contribute to latent heat flux.

The other sensor pair is initially uncalibrated but has much faster response times and can measure the variance of almost all the eddies contributing to the vapor flux. As the ATMOS 51 runs, the processor collects data from both pairs of sensors and auto-calibrates the fast-response sensors. The readings from the fast response sensors are then used to determine the variance Bowen ratio. A digital high pass filter, applied to the data, sets the time constant for the largest eddies measured at around 200 seconds. The response time of the fast sensors sets the time constant for sensing the smallest eddies at around 0.1 seconds. This means the ATMOS 51 VBR ET Sensor responds to eddies in the size range from 0.1 to 200 s. Eddies in this size range account for almost all of the vapor flux in the atmosphere.

[Figure 6](#) shows the measuring and processing scheme for computing the Bowen ratio. First, compute specific humidity from measurements of temperature and humidity. Second, high-pass filter the temperature and specific humidity readings to take out the mean values, and then compute the variances and covariance. Third, sample once per second and keep a running average of all the quantities. The variance Bowen ratio is computed from the ratio of standard deviations of temperature and specific humidity. Unfortunately, the sign of the ratio of two variances will always be positive, leading to ET errors in advective conditions. The ATMOS 51 uses a patent pending technique to assess temperature and vapor covariance to ensure the Bowen ratio has the correct sign (see [Section 3.7](#) for more details).

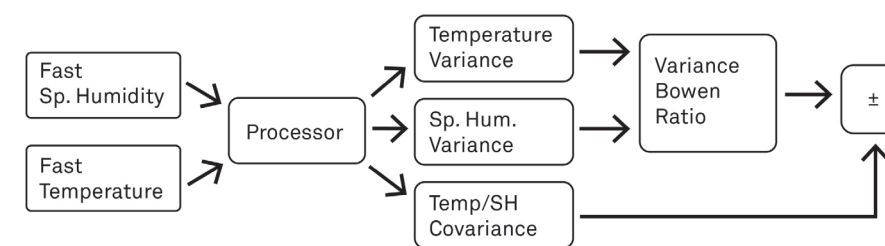

Figure 6 Humidity and temperature processing to compute the variance Bowen ratio

Once the Bowen ratio has the correct sign, it can be used to compute the evapotranspiration for the soil or crop surface, shown in the next figure (Figure 7). The solar radiation measurement comes from the pyranometer on the top of the sensor. Temperature, humidity, location and time also come from the sensors. The processor uses those inputs to model net radiation and soil heat flux.

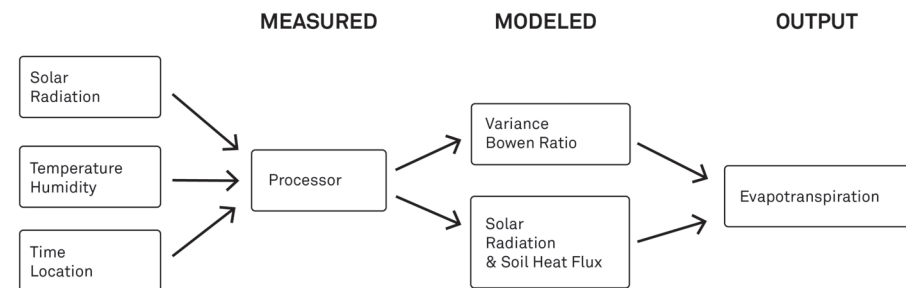

Figure 7 Processing of environmental data to determine evapotranspiration

Some assumptions are made for this model, and the user needs to be aware of those in order to avoid misusing the data. The ATMOS 51 VBR ET Sensor models net radiation and soil heat flux from solar radiation, air temperature, vapor pressure, location, and time (Campbell and Norman, 1998). This works well for typical crops where little direct radiation reaches the soil surface. For sparse or dead vegetation, with little latent heat flux, the surface albedo may differ substantially from the value assumed in the model ($\alpha = 0.23$), soil heat flux may also be greater than is assumed in the model ($G = 0.1 \cdot R_n$), while emitted radiation may differ from the assumption that surface and air temperature are equal. Correct measurements of ET in these conditions likely will require direct measurement of net radiation and soil heat flux. The sensor still outputs Bowen ratio, so those measurements can be used to get ET, but the ET value output by the ATMOS 51 VBR ET Sensor will probably be too high.

3.7 THEORY

The evaporation of water from a crop, wet soil, or natural water surface consumes a significant fraction of the total energy available at the surface. At steady state, the energy balance equation can be written as:

$$R_n - G - H - \lambda E = 0$$

Equation 1

Where R_n is the net radiation, G represents the flux of heat into the soil, H represents the sensible heat flux into the atmosphere, and λE is the latent heat going to evaporate water. Other fluxes, such as photosynthesis, are sometimes included, but, at most, they are 5% of the total. Since net radiation and soil heat flux are fairly easy to measure, and latent heat flux is often a significant fraction of the total, the energy balance is often used to measure the latent heat flux, or evapotranspiration from the surface. This, of course, requires a method for determining H .

Since the work of Bowen (1926), almost a century ago, it is common to make a ratio of the sensible to latent heat flux, called a Bowen ratio.

$$\beta = \frac{H}{\lambda E}$$

Equation 2

Substituting this into eq. 1 and solving for latent heat flux gives:

$$\lambda E = \frac{R_n - G}{1 + \beta}$$

Equation 3

Various ways of finding the Bowen ratio have been tried over the years. Typically it has been done by measuring temperature and vapor pressure differences at two heights, and taking a ratio of them. Those differences, however, are typically very small, and inherent measurement errors make it very difficult to get reliable Bowen ratios. A new, more reliable method was published in 2023 by Wang, et al. (2023). The derivation of the method is shown in the following equation:

$$\beta_v = \frac{H}{\lambda E} = \frac{\rho \cdot c_p \cdot \overline{w'T'}}{\lambda \cdot \rho \cdot \overline{w'q'}} = \frac{c_p}{\lambda} \cdot \frac{r_{wT} \cdot \sigma_w \cdot \sigma_T}{r_{wq} \cdot \sigma_w \cdot \sigma_q} = \frac{c_p}{\lambda} \cdot \frac{\sigma_T}{\sigma_q}$$

Equation 4

Where ρ is air density, c_p is air specific heat, w is vertical wind velocity, T is temperature, q is specific humidity, λ is latent heat of evaporation, the r_{wT} and r_{wq} are correlation coefficients, the σ_T and σ_q are standard deviations, and γ is the psychrometer constant, c_p/λ . Primes indicate deviations from the mean value, and overbars mean average. The expressions after the second equal sign are for eddy covariance of heat and water vapor. It is assumed that the correlation coefficients for heat and water vapor are equal, so divide it out. The standard