

# TABLE OF CONTENTS

<b>1. Introduction</b> .....	1
<b>2. Operation</b> .....	3
2.1 Installation .....	3
<b>3. System</b> .....	6
3.1 Specifications.....	6
3.2 Components .....	11
3.2.1 Gateway .....	11
3.2.2 Repeater and Climate Station .....	13
3.2.3 Sensor Nose .....	15
<b>4. Service</b> .....	17
4.1 Maintenance .....	17
4.2 Repairs .....	17
4.3 Troubleshooting .....	18
4.4 Customer Support .....	21
4.5 Terms and Conditions .....	21
<b>APPENDIX A. Compliance Certifications</b> .....	22
A.1 USA.....	22
A.2 CANADA .....	24

# 1. INTRODUCTION

Thank you for choosing the AROYA system from METER Group. Prior to use, verify the sensor arrived in good condition.

The AROYA system works in a wireless mesh network. A wireless mesh network allows data and files to be transferred from one device to another through wireless transmission. The AROYA system components are FCC approved (Class A) and can communicate wirelessly between each other. The Gateway, Repeater, and Climate Station all use Power over Ethernet (PoE) that is compliant with IEEE 802.3af PoE standards.

The AROYA Gateway ([Figure 6](#) and [Figure 7](#)) sends and receives data transmitted by the Repeater or Sensor Nose and provides the system with an active connection to the cloud server where all data is processed and presented to the user.

The AROYA Repeater ([Figure 8](#)) functions as a range extender, receiving data from the Sensor Nose and transmitting data wirelessly to the Gateway.

The AROYA Climate Station ([Figure 9](#)) includes a Repeater and an ATMOS 14 temperature and relative humidity (RH) sensor. The ATMOS 14 supports SDI-12 sensor communication to capture microclimate sensor data. Data collected by the sensor is transmitted wirelessly to the Gateway.

The AROYA Sensor Nose ([Figure 10](#) and [Figure 11](#)) has communication components and an antenna to transmit data to the Repeater or directly to the Gateway if the Sensor Nose is close enough. The Sensor Nose connects to a variety of sensors.

### AROYA System Configuration

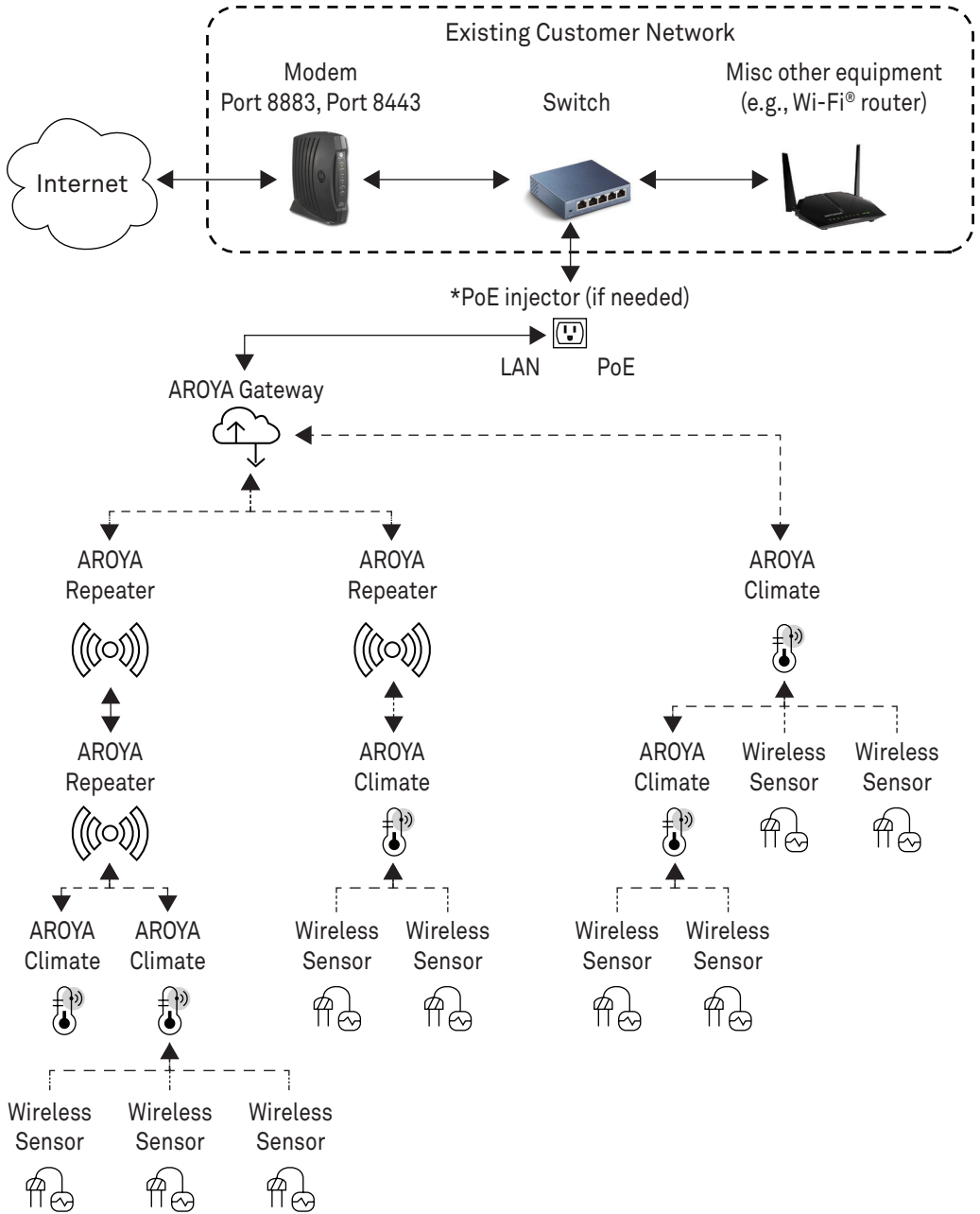

Figure 1 AROYA wireless mesh network

## 2. OPERATION

Please read all instructions before operating AROYA sensors to ensure it performs to its full potential.

### PRECAUTIONS

METER sensors are built to the highest standards, but misuse, improper protection, or improper installation may damage the sensor and possibly void the manufacturer’s warranty. Before integrating AROYA into a system, make sure to follow the recommended installation instructions and have the proper protections in place to safeguard sensors from damage.

## 2.1 INSTALLATION

Follow the steps listed in [Table 1](#) to set up the Gateway.

**Table 1 Gateway Installation**

<b>Tools Needed</b>	<p>Cordless drill</p> <p>Screw driver</p> <p>Screws</p>
<b>Preparation</b>	<p><b>Consider the Surroundings</b></p> <p>Locate the Gateway in a hallway or office with internet access for PoE. The site network infrastructure will determine what installation method is required so the Gateway can communicate with other parts of the system. If this is not possible, locate the Gateway wherever there is access to connections required to establish communication.</p> <p>The Gateway needs to be close enough to the Repeater(s) for the signal from the Repeater to reach the Gateway.</p> <p><b>Verify Internet Connectivity</b></p> <p>Log into the AROYA software or mobile app.</p> <p>Go to the <b>Devices</b> pages.</p> <p>Select Gateway under <b>All Devices</b>.</p> <p>A check mark icon indicates the Gateway is connected to the internet.</p>
<b>Mounting</b>	<p>METER recommends putting the Gateway on a table or shelf.</p>
<b>Configuration</b>	<p>All system configuration work is done at METER before installation occurs at the customer site.</p>

## OPERATION

Follow the steps listed in [Table 2](#) to set up the AROYA Repeater.

**Table 2 Repeater Installation**

<b>Preparation</b>	<b>Consider the Surroundings</b> METER recommends installing the Repeater in the hallways about shoulder height to enhance transmission of data from sensors throughout the facility back to the Gateway.
<b>Mounting</b>	Install the Repeater at approximately shoulder height in a hallway. Use screws inserted into the mounting bracket to secure to wall.
<b>Configuration</b>	All system configuration work is done at METER before installation occurs at the customer site.
<b>Connecting</b>	<b>Connect Repeater to PoE and Verify</b> Connect one end of this cable to the Repeater ( <a href="#">Figure 8</a> ) and the other to the PoE Router or a PoE injector.  Verify the Repeater is connected to the internet and functional by looking through the device page in AROYA or looking for a steady blue LED light on the surface shown in <a href="#">Figure 8</a> .

Follow the steps listed in [Table 3](#) to set up the AROYA Climate Station.

**Table 3 Climate Station Installation**

<b>Tools Needed</b>	Grow light hanger (e.g., rope ratchet clip hanger) Chain, cable, or rope
<b>Preparation</b>	<b>Consider the Surroundings</b> METER recommends installing the Climate Station in the center of each room of the greenhouse to facilitate quality communication to the Gateway.  The Climate Station should be in an area where the environment is as consistent as possible. If a fogger is set up in the center of a room, set up the Repeater in a location away from the fogger.
<b>Mounting</b>	METER recommends installing the Climate Station in the center of the room just over the canopy using the light hanger pulley provided.
<b>Configuration</b>	The Climate Station needs to be assigned to the room that it is installed in.
<b>Connecting</b>	<b>Connect Climate Station to PoE and Verify</b> Securely hold the cable gland on the Climate Station side, and unscrew the outer cover from the side that is open. Remove the the cap and grommet. Follow the steps below, referring to <a href="#">Figure 2</a> . <ul style="list-style-type: none"><li>• Slide the water-tight coupling pieces onto the PoE Ethernet cable in the following order: cap, blue seal grommet, outer cover.</li><li>• Plug the PoE connector into the coupling.</li><li>• Screw the outer cover onto the coupling and tighten.</li><li>• Slide and push the blue seal grommet into the outer cover flexible prongs.</li><li>• Screw the cap onto the outer cover, over the grommet, and tighten (do not overtighten).</li></ul>

**Table 3 Climate Station Installation (continued)**

**Connecting  
(continued)**

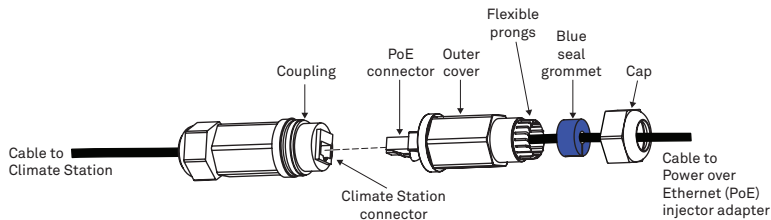

**Figure 2 Water-tight coupling**

Verify the Climate Station is connected to the internet and functional by looking through the devices page in AROYA or looking for a steady blue LED light on the surface shown in [Figure 9](#).

Follow the steps in [Table 4](#) to set up the AROYA Sensor Nose.

**Table 4 Sensor Nose Installation**

<b>Tools Needed</b>	AROYA Sensor Nose
<b>Preparation</b>	<b>Consider the Surroundings</b> The TEROS 12 needles are inserted into the substrate.
	<b>Check Sensor Functionality</b> Press the function button ( <a href="#">Figure 10</a> ) until the LED flashes green.
<b>Mounting</b>	Insert sensor into slabs or larger substrate types.
<b>Configuration</b>	All system configuration work is done at METER before installation occurs at the customer site.
<b>Connecting</b>	<b>Wake Sensor Nose and Verify</b> The Sensor Nose is shipped to the customer in SLEEP mode, indicated by a solid red status LED light on the end where the cable is connected.
	Press the button until a green LED light appears.
	Press the button one more time then stop. Status LED shows green when the unit has entered the ON mode. If button is pressed too many times it will flash red and go back to sleep.

### 3. SYSTEM

This section describes the specifications and components of the AROYA Gateway, Repeater, Climate Station, and Sensor Nose.

#### 3.1 SPECIFICATIONS

##### MEASUREMENT SPECIFICATION

###### ATMOS 14 Temperature and Relative Humidity (RH) Sensor

###### Relative Humidity (RH)

Range	0–100% RH (0.00–1.00)																																																																																																																																				
Resolution	0.10% RH																																																																																																																																				
Accuracy	<p>Sensor measurement accuracy is variable across a range of RH. Refer to the chart in <a href="#">Figure 3</a>.</p> <table border="1"> <tr> <td rowspan="11">HUMIDITY (%RH)</td> <td>100</td> <td>±2.0%</td> <td>±2.0%</td> <td>±2.0%</td> <td>±2.0%</td> <td>±2.0%</td> <td>±2.0%</td> <td>±2.0%</td> <td>±2.0%</td> <td>±2.0%</td> </tr> <tr> <td>90</td> <td>±2.0%</td> <td>±2.0%</td> <td>±2.0%</td> <td>±2.0%</td> <td>±2.0%</td> <td>±2.0%</td> <td>±2.0%</td> <td>±2.0%</td> <td>±2.0%</td> </tr> <tr> <td>80</td> <td>±2.0%</td> <td>±1.5%</td> <td>±1.5%</td> <td>±1.5%</td> <td>±1.5%</td> <td>±1.5%</td> <td>±2.0%</td> <td>±2.0%</td> <td>±2.0%</td> </tr> <tr> <td>70</td> <td>±1.5%</td> <td>±1.5%</td> <td>±1.5%</td> <td>±1.5%</td> <td>±1.5%</td> <td>±1.5%</td> <td>±1.5%</td> <td>±2.0%</td> <td>±2.0%</td> </tr> <tr> <td>60</td> <td>±1.5%</td> <td>±1.5%</td> <td>±1.5%</td> <td>±1.5%</td> <td>±1.5%</td> <td>±1.5%</td> <td>±1.5%</td> <td>±2.0%</td> <td>±2.0%</td> </tr> <tr> <td>50</td> <td>±1.5%</td> <td>±1.5%</td> <td>±1.5%</td> <td>±1.5%</td> <td>±1.5%</td> <td>±1.5%</td> <td>±1.5%</td> <td>±2.0%</td> <td>±2.0%</td> </tr> <tr> <td>40</td> <td>±1.5%</td> <td>±1.5%</td> <td>±1.5%</td> <td>±1.5%</td> <td>±1.5%</td> <td>±1.5%</td> <td>±1.5%</td> <td>±1.5%</td> <td>±2.0%</td> </tr> <tr> <td>30</td> <td>±1.5%</td> <td>±1.5%</td> <td>±1.5%</td> <td>±1.5%</td> <td>±1.5%</td> <td>±1.5%</td> <td>±1.5%</td> <td>±1.5%</td> <td>±2.0%</td> </tr> <tr> <td>20</td> <td>±1.5%</td> <td>±1.5%</td> <td>±1.5%</td> <td>±1.5%</td> <td>±1.5%</td> <td>±1.5%</td> <td>±1.5%</td> <td>±1.5%</td> <td>±2.0%</td> </tr> <tr> <td>10</td> <td>±1.5%</td> <td>±1.5%</td> <td>±1.5%</td> <td>±1.5%</td> <td>±1.5%</td> <td>±1.5%</td> <td>±1.5%</td> <td>±1.5%</td> <td>±2.0%</td> </tr> <tr> <td>0</td> <td>±1.5%</td> <td>±1.5%</td> <td>±1.5%</td> <td>±1.5%</td> <td>±1.5%</td> <td>±1.5%</td> <td>±1.5%</td> <td>±1.5%</td> <td>±2.0%</td> </tr> <tr> <td></td> <td>0</td> <td>10</td> <td>20</td> <td>30</td> <td>40</td> <td>50</td> <td>60</td> <td>70</td> <td>80</td> </tr> <tr> <td></td> <td colspan="10" style="text-align: center;">TEMPERATURE (°C)</td> </tr> </table> <p style="text-align: center;"><b>Figure 3 RH sensor accuracy</b></p>	HUMIDITY (%RH)	100	±2.0%	±2.0%	±2.0%	±2.0%	±2.0%	±2.0%	±2.0%	±2.0%	±2.0%	90	±2.0%	±2.0%	±2.0%	±2.0%	±2.0%	±2.0%	±2.0%	±2.0%	±2.0%	80	±2.0%	±1.5%	±1.5%	±1.5%	±1.5%	±1.5%	±2.0%	±2.0%	±2.0%	70	±1.5%	±1.5%	±1.5%	±1.5%	±1.5%	±1.5%	±1.5%	±2.0%	±2.0%	60	±1.5%	±1.5%	±1.5%	±1.5%	±1.5%	±1.5%	±1.5%	±2.0%	±2.0%	50	±1.5%	±1.5%	±1.5%	±1.5%	±1.5%	±1.5%	±1.5%	±2.0%	±2.0%	40	±1.5%	±1.5%	±1.5%	±1.5%	±1.5%	±1.5%	±1.5%	±1.5%	±2.0%	30	±1.5%	±1.5%	±1.5%	±1.5%	±1.5%	±1.5%	±1.5%	±1.5%	±2.0%	20	±1.5%	±1.5%	±1.5%	±1.5%	±1.5%	±1.5%	±1.5%	±1.5%	±2.0%	10	±1.5%	±1.5%	±1.5%	±1.5%	±1.5%	±1.5%	±1.5%	±1.5%	±2.0%	0	±1.5%	±1.5%	±1.5%	±1.5%	±1.5%	±1.5%	±1.5%	±1.5%	±2.0%		0	10	20	30	40	50	60	70	80		TEMPERATURE (°C)									
HUMIDITY (%RH)	100		±2.0%	±2.0%	±2.0%	±2.0%	±2.0%	±2.0%	±2.0%	±2.0%	±2.0%																																																																																																																										
	90		±2.0%	±2.0%	±2.0%	±2.0%	±2.0%	±2.0%	±2.0%	±2.0%	±2.0%																																																																																																																										
	80		±2.0%	±1.5%	±1.5%	±1.5%	±1.5%	±1.5%	±2.0%	±2.0%	±2.0%																																																																																																																										
	70		±1.5%	±1.5%	±1.5%	±1.5%	±1.5%	±1.5%	±1.5%	±2.0%	±2.0%																																																																																																																										
	60		±1.5%	±1.5%	±1.5%	±1.5%	±1.5%	±1.5%	±1.5%	±2.0%	±2.0%																																																																																																																										
	50		±1.5%	±1.5%	±1.5%	±1.5%	±1.5%	±1.5%	±1.5%	±2.0%	±2.0%																																																																																																																										
	40		±1.5%	±1.5%	±1.5%	±1.5%	±1.5%	±1.5%	±1.5%	±1.5%	±2.0%																																																																																																																										
	30		±1.5%	±1.5%	±1.5%	±1.5%	±1.5%	±1.5%	±1.5%	±1.5%	±2.0%																																																																																																																										
	20		±1.5%	±1.5%	±1.5%	±1.5%	±1.5%	±1.5%	±1.5%	±1.5%	±2.0%																																																																																																																										
	10		±1.5%	±1.5%	±1.5%	±1.5%	±1.5%	±1.5%	±1.5%	±1.5%	±2.0%																																																																																																																										
	0	±1.5%	±1.5%	±1.5%	±1.5%	±1.5%	±1.5%	±1.5%	±1.5%	±2.0%																																																																																																																											
	0	10	20	30	40	50	60	70	80																																																																																																																												
	TEMPERATURE (°C)																																																																																																																																				
Equilibration Time ( $\tau$ , 63%)	<25 s (response time in 1 m/s air stream)																																																																																																																																				
Hysteresis	±0.80% RH, typical																																																																																																																																				
Long-Term Drift	±0.25% RH/year, typical																																																																																																																																				
<b>Temperature</b>																																																																																																																																					
Range	–40 to 80 °C																																																																																																																																				
Resolution	0.1 °C																																																																																																																																				

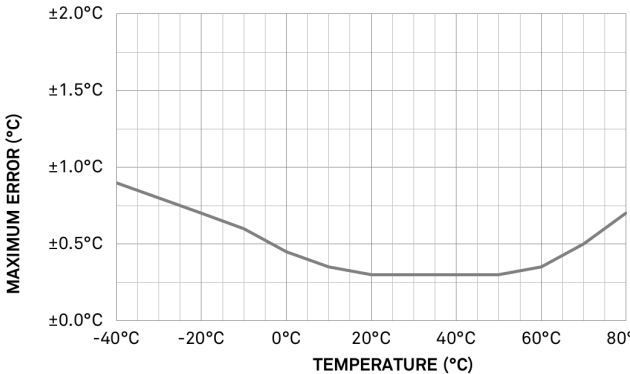
<p>Accuracy</p>	<p>Sensor measurement accuracy is variable across a range of temperatures. Refer to the chart in <a href="#">Figure 4</a>.</p>  <p style="text-align: center;"><b>Figure 4 Temperature sensor accuracy</b></p>																																																																																																																																				
<p>Equilibration Time (<math>\tau</math>, 63%)</p>	<p>&lt;165 s (response time in 1 m/s air stream)</p>																																																																																																																																				
<p>Long-Term Drift</p>	<p>&lt;0.03 °C/year, typical</p>																																																																																																																																				
<p><b>Vapor Pressure</b></p>																																																																																																																																					
<p>Range</p>	<p>0–47 kPa</p>																																																																																																																																				
<p>Resolution</p>	<p>0.01 kPa</p>																																																																																																																																				
<p>Accuracy</p>	<p>Sensor measurement accuracy is variable across a range of temperature and RH. Refer to the chart in <a href="#">Figure 5</a>.</p> <table border="1" data-bbox="506 987 1112 1318"> <tr> <td rowspan="10" style="writing-mode: vertical-rl; transform: rotate(180deg);">HUMIDITY (%RH)</td> <td>100</td><td>± 0.03</td><td>± 0.05</td><td>± 0.09</td><td>± 0.16</td><td>± 0.27</td><td>± 0.44</td><td>± 0.69</td><td>± 1.33</td><td>± 2.38</td> </tr> <tr> <td>90</td><td>± 0.03</td><td>± 0.05</td><td>± 0.09</td><td>± 0.15</td><td>± 0.26</td><td>± 0.42</td><td>± 0.66</td><td>± 1.26</td><td>± 2.24</td> </tr> <tr> <td>80</td><td>± 0.03</td><td>± 0.04</td><td>± 0.07</td><td>± 0.12</td><td>± 0.21</td><td>± 0.34</td><td>± 0.63</td><td>± 1.20</td><td>± 2.10</td> </tr> <tr> <td>70</td><td>± 0.02</td><td>± 0.04</td><td>± 0.07</td><td>± 0.12</td><td>± 0.20</td><td>± 0.32</td><td>± 0.50</td><td>± 1.13</td><td>± 1.96</td> </tr> <tr> <td>60</td><td>± 0.02</td><td>± 0.03</td><td>± 0.06</td><td>± 0.11</td><td>± 0.18</td><td>± 0.30</td><td>± 0.47</td><td>± 1.06</td><td>± 1.82</td> </tr> <tr> <td>50</td><td>± 0.02</td><td>± 0.03</td><td>± 0.06</td><td>± 0.10</td><td>± 0.17</td><td>± 0.28</td><td>± 0.45</td><td>± 0.99</td><td>± 1.68</td> </tr> <tr> <td>40</td><td>± 0.02</td><td>± 0.03</td><td>± 0.05</td><td>± 0.09</td><td>± 0.16</td><td>± 0.26</td><td>± 0.42</td><td>± 0.76</td><td>± 1.54</td> </tr> <tr> <td>30</td><td>± 0.01</td><td>± 0.03</td><td>± 0.05</td><td>± 0.09</td><td>± 0.15</td><td>± 0.24</td><td>± 0.39</td><td>± 0.69</td><td>± 1.40</td> </tr> <tr> <td>20</td><td>± 0.01</td><td>± 0.02</td><td>± 0.04</td><td>± 0.08</td><td>± 0.14</td><td>± 0.23</td><td>± 0.36</td><td>± 0.62</td><td>± 1.26</td> </tr> <tr> <td>10</td><td>± 0.01</td><td>± 0.02</td><td>± 0.04</td><td>± 0.07</td><td>± 0.12</td><td>± 0.21</td><td>± 0.33</td><td>± 0.55</td><td>± 1.13</td> </tr> <tr> <td>0</td><td>± 0.01</td><td>± 0.02</td><td>± 0.04</td><td>± 0.06</td><td>± 0.11</td><td>± 0.19</td><td>± 0.30</td><td>± 0.48</td><td>± 0.99</td> </tr> <tr> <td></td> <td>0</td><td>10</td><td>20</td><td>30</td><td>40</td><td>50</td><td>60</td><td>70</td><td>80</td> </tr> <tr> <td></td> <td colspan="10" style="text-align: center;">TEMPERATURE (°C)</td> </tr> </table> <p style="text-align: center;"><b>Figure 5 Vapor pressure sensor accuracy</b></p>	HUMIDITY (%RH)	100	± 0.03	± 0.05	± 0.09	± 0.16	± 0.27	± 0.44	± 0.69	± 1.33	± 2.38	90	± 0.03	± 0.05	± 0.09	± 0.15	± 0.26	± 0.42	± 0.66	± 1.26	± 2.24	80	± 0.03	± 0.04	± 0.07	± 0.12	± 0.21	± 0.34	± 0.63	± 1.20	± 2.10	70	± 0.02	± 0.04	± 0.07	± 0.12	± 0.20	± 0.32	± 0.50	± 1.13	± 1.96	60	± 0.02	± 0.03	± 0.06	± 0.11	± 0.18	± 0.30	± 0.47	± 1.06	± 1.82	50	± 0.02	± 0.03	± 0.06	± 0.10	± 0.17	± 0.28	± 0.45	± 0.99	± 1.68	40	± 0.02	± 0.03	± 0.05	± 0.09	± 0.16	± 0.26	± 0.42	± 0.76	± 1.54	30	± 0.01	± 0.03	± 0.05	± 0.09	± 0.15	± 0.24	± 0.39	± 0.69	± 1.40	20	± 0.01	± 0.02	± 0.04	± 0.08	± 0.14	± 0.23	± 0.36	± 0.62	± 1.26	10	± 0.01	± 0.02	± 0.04	± 0.07	± 0.12	± 0.21	± 0.33	± 0.55	± 1.13	0	± 0.01	± 0.02	± 0.04	± 0.06	± 0.11	± 0.19	± 0.30	± 0.48	± 0.99		0	10	20	30	40	50	60	70	80		TEMPERATURE (°C)									
HUMIDITY (%RH)	100		± 0.03	± 0.05	± 0.09	± 0.16	± 0.27	± 0.44	± 0.69	± 1.33	± 2.38																																																																																																																										
	90		± 0.03	± 0.05	± 0.09	± 0.15	± 0.26	± 0.42	± 0.66	± 1.26	± 2.24																																																																																																																										
	80		± 0.03	± 0.04	± 0.07	± 0.12	± 0.21	± 0.34	± 0.63	± 1.20	± 2.10																																																																																																																										
	70		± 0.02	± 0.04	± 0.07	± 0.12	± 0.20	± 0.32	± 0.50	± 1.13	± 1.96																																																																																																																										
	60		± 0.02	± 0.03	± 0.06	± 0.11	± 0.18	± 0.30	± 0.47	± 1.06	± 1.82																																																																																																																										
	50		± 0.02	± 0.03	± 0.06	± 0.10	± 0.17	± 0.28	± 0.45	± 0.99	± 1.68																																																																																																																										
	40		± 0.02	± 0.03	± 0.05	± 0.09	± 0.16	± 0.26	± 0.42	± 0.76	± 1.54																																																																																																																										
	30		± 0.01	± 0.03	± 0.05	± 0.09	± 0.15	± 0.24	± 0.39	± 0.69	± 1.40																																																																																																																										
	20		± 0.01	± 0.02	± 0.04	± 0.08	± 0.14	± 0.23	± 0.36	± 0.62	± 1.26																																																																																																																										
	10	± 0.01	± 0.02	± 0.04	± 0.07	± 0.12	± 0.21	± 0.33	± 0.55	± 1.13																																																																																																																											
0	± 0.01	± 0.02	± 0.04	± 0.06	± 0.11	± 0.19	± 0.30	± 0.48	± 0.99																																																																																																																												
	0	10	20	30	40	50	60	70	80																																																																																																																												
	TEMPERATURE (°C)																																																																																																																																				



## SYSTEM

### Barometric Pressure

Range	1–120 kPa
Resolution	0.01 kPa
Accuracy	±0.05 kPa at 25 °C

### TEROS 12 Soil Moisture, Temperature, and Electrical Conductivity (EC) Sensor

#### Volumetric Water Content (VWC)

Range	
Mineral soil calibration	0.00–0.70 m <sup>3</sup> /m <sup>3</sup>
Soilless media	0.0–1.0 m <sup>3</sup> /m <sup>3</sup>
Apparent dielectric permittivity ( $\epsilon_a$ )	1 (air) to 80 (water)

**NOTE:** The VWC range is dependent on the media the sensor is calibrated to. A custom calibration will accommodate the necessary ranges for most substrates.

Resolution	0.001 m <sup>3</sup> /m <sup>3</sup>
Accuracy	
Generic calibration	±0.03 m <sup>3</sup> /m <sup>3</sup> typical in mineral soils that thave solution EC <8 dS/m
Medium specific calibration	±0.01–0.02 m <sup>3</sup> /m <sup>3</sup> in any porous medium
Apparent dielectric permittivity ( $\epsilon_a$ )	1–40 (soil range), ±1 $\epsilon_a$ (unitless) 40–80, 15% of measurement

#### Dielectric Measurement Frequency

70 MHz

### TEROS 12 Temperature

Range	–40 to +60 °C
Resolution	0.1 °C
Accuracy	±0.5 °C from –40 to 0 °C ±0.3 °C from 0 to +60 °C

#### Bulk Electrical Conductivity (EC) (TEROS 12 Only)

Range	0–20 dS/m (bulk)
Resolution	0.001 dS/m
Accuracy	±(5% + 0.01 dS/m) from 0–10 dS/m ±8% from 10–20 dS/m

## COMMUNICATION SPECIFICATIONS

Output	
Gateway	Ethernet (PoE)
Wireless communication	Wireless mesh (Gateway, Repeaters, Sensors)
Sensor types	SDI-12 based
Antenna	
Make	Raltron
Model number	RST-W2-P-110-SMA-H
Gain	4.15 dBi vertically polarized, dipole professionally installed

**NOTE:** This radio transmitter IC-5123A-MGM12P0 has been approved by Innovation, Science and Economic Development Canada to operate with the antenna types listed below, with the maximum permissible gain indicated. Antenna types not included in this list that have a gain greater than the maximum gain indicated for any type listed are strictly prohibited for use with this device. Maximum Gain: 4.15 dBi Vertically polarized, dipole.

## PHYSICAL SPECIFICATIONS

Dimensions	
Antenna	11.5 cm (4.53 in) <b>NOTE: Antenna is positioned straight out adding to the total length.</b>
Gateway	
Length	14.5 cm (5.71 in)
Width	10.5 cm (4.13 in)
Height	4.5 cm (1.78 in)
Repeater	
Length	14.6 cm (5.75 in)
Width	10.2 cm (4.00 in)
Height	14.3 cm (5.63 in)
Climate Station	
Length	15.5 cm (6.10 in)
Width	8.5 cm (3.35 in)
Height	3.7 cm (1.46 in)

## SYSTEM

### ATMOS 14 w/radiation shield

Diameter	10.0 cm (3.94 in)
Height	8.5 cm (3.35 in)
Sensor Station	
Length	6.99 cm (2.75 in)
Width	18.00 cm (7.10 in)
Height	3.02 cm (1.19 in)

### TEROS 12

Length	9.4 cm (3.70 in)
Width	2.4 cm (0.95 in)
Height	7.5 cm (2.95 in)
Needle length	5.5 cm (2.17 in)

### Operating Temperature Range

Minimum	-40 °C
Typical	50 °C
Maximum	80 °C

**NOTE:** Sensors may be used at higher temperatures under certain conditions; contact [Customer Support](#) for assistance.

### Cable

CAT 5E or better for all equipment

### Connector Types

Gateway power	RJ 45 PoE
Repeater power	RJ 45 PoE
Climate Station power	RJ 45 PoE
ATMOS 14 and TEROS 12 sensor connection	M8 4-pin (Sensor Station, Repeater, Climate Station)
Communications port	M8 4-pin (Sensor Station, Repeater, Climate Station)

## ELECTRICAL CHARACTERISTICS

Power	
Lithium-ion (Li-on) rechargeable battery	Battery cannot be replaced by the user. <b>NOTE: The Gateway device does NOT have a battery. It is powered over Ethernet (PoE).</b>
Power over Ethernet (PoE)	42.5–57.0 V, up to 25.5 W
<b>CAUTION: If using a nonmanufacturer supplied PoE device to power this system, ensure that the voltage rating does not exceed the recommended values stated above. The injector module used must comply with IEEE 802.3af and must be able to supply at least 24 W for the Gateway to function as intended.</b>	

## COMPLIANCE

Manufactured under ISO 9001:2015

## 3.2 COMPONENTS

This sections describes the components of the AROYA system.

### 3.2.1 GATEWAY

The Gateway provides sensor readings received from either a Repeater/Climate Station ([Section 3.2.2](#)) or Sensor Station ([Section 3.2.3](#)) to the AROYA app for the customer to review. The indicator light flashes orange when the device is powered from a PoE switch. Ensure the device is powered by a device that supplies both Ethernet and power. The cable must be an RJ 45 CAT 5E or better.

The Gateway operates using the following components:

- Power over Ethernet (PoE) module for continuous power
- 2.4-GHz wireless low-energy chip antenna

# SYSTEM

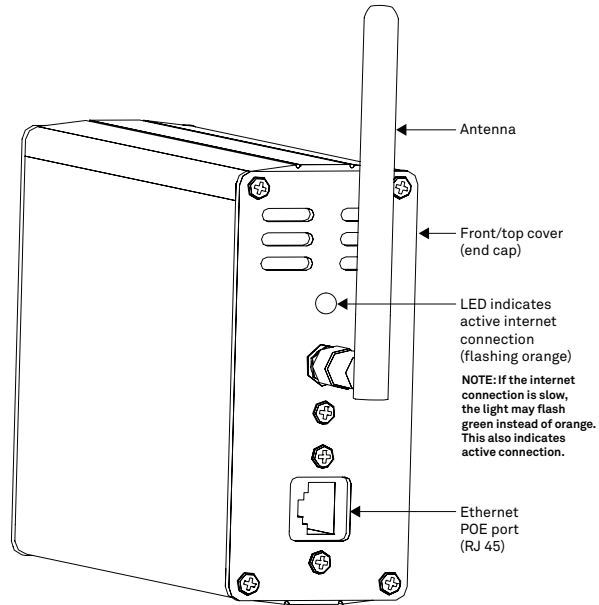

Figure 6 AROYA Gateway—front, top view

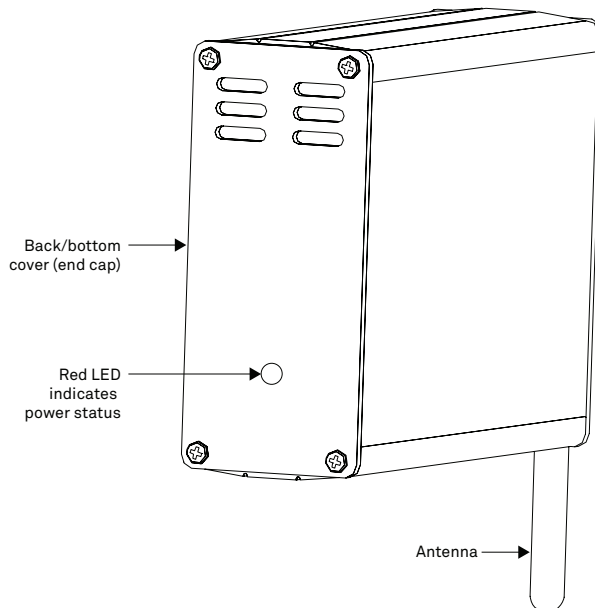
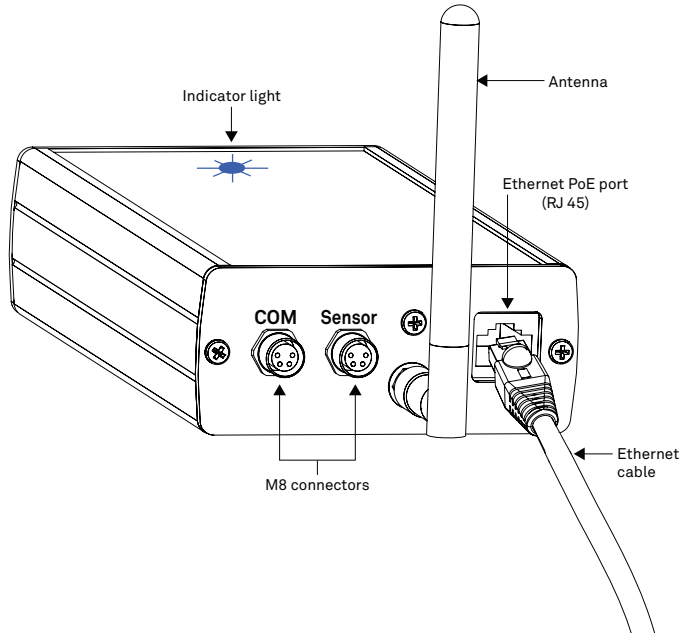

Figure 7 AROYA Gatewayback, bottom view

### 3.2.2 REPEATER AND CLIMATE STATION

The AROYA Repeater/Climate Station receives data from the Sensor Nose and transmits data to the gateway wirelessly. The Repeater acts as a range extension for the network and funnels the data to the Gateway device. The Repeater operates on a wireless mesh network and relies on an active PoE connection to supply power to the device.



**Figure 8 AROYA Repeater—front, top view**

The Repeater and Climate Station both operate using the following components:

- PoE module for continuous power
- Rechargeable lithium-ion battery for back-up power
- 2.4-GHz two-way antenna for wireless communication
- 38.4-MHz oscillator for high frequency, precise timing reference
- 32.768-kHz oscillator for low-frequency, low-energy timing reference

The AROYA Climate Station receives data from the Sensor Nose and transmits data to the Gateway wirelessly. The ATMOS 14, located in a radiation shield and attached to the Climate Station, collects microclimate data that is also transmitted to the Gateway. The radiation shield comprises a mounting bracket and seven discs. The shield prevents direct sunlight from coming into contact with the sensor. This isolation from solar radiation prevents false readings of elevated temperatures, allowing for accurate measurement of ambient air temperature.

# SYSTEM

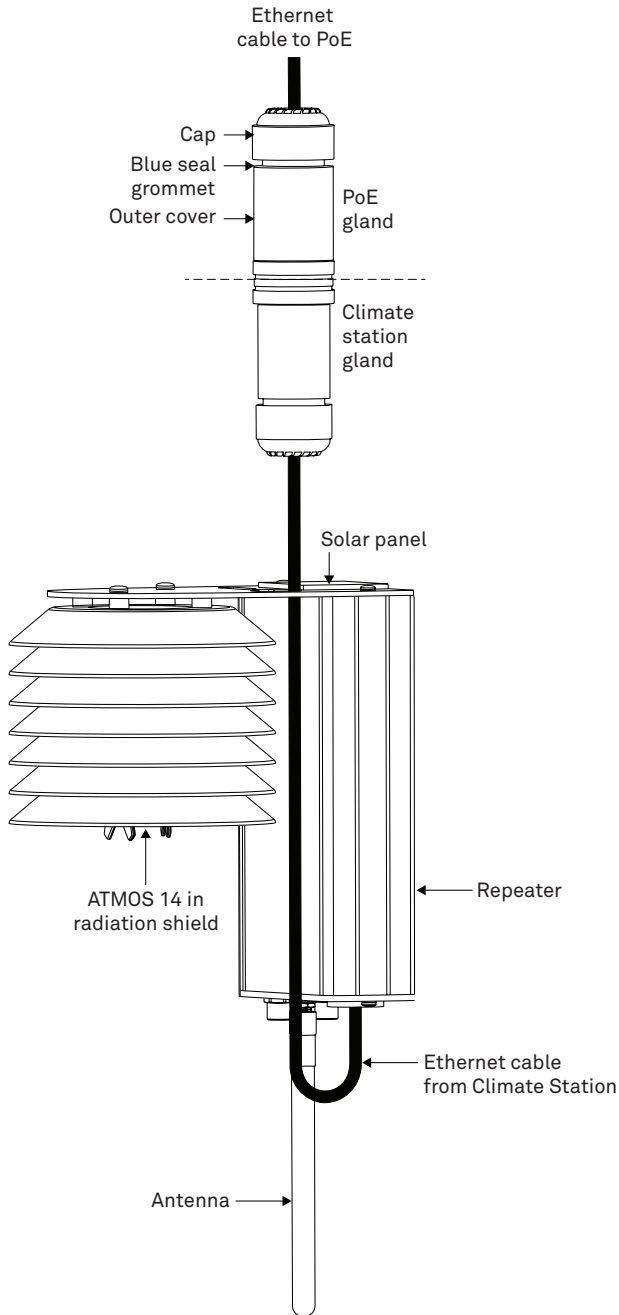

Figure 9 AROYA Climate Station—front, top view

### 3.2.3 SENSOR NOSE

Figure 10 and Figure 11 show the AROYA Sensor Nose. The Sensor Nose contain a TEROS 12 soil moisture sensor, location for plant, communication components, and antenna to communicate data gathered by the TEROS 12 to the Repeater or directly to the gateway if the base is close enough.

The Sensor Nose operates using the following components:

- Rechargeable lithium-ion battery
- Solar Panels for energy harvesting
- 2.4-GHz two-way antenna for wireless communication
- 38.4-MHz oscillator for high frequency, precise timing reference
- 32.768-kHz oscillator for low-frequency, low-energy timing reference

The AROYA Sensor Nose allows the TEROS 12 prongs to be inserted into the side of slabs. The Sensor Nose is powered with a lithium-ion battery that is solar charged.

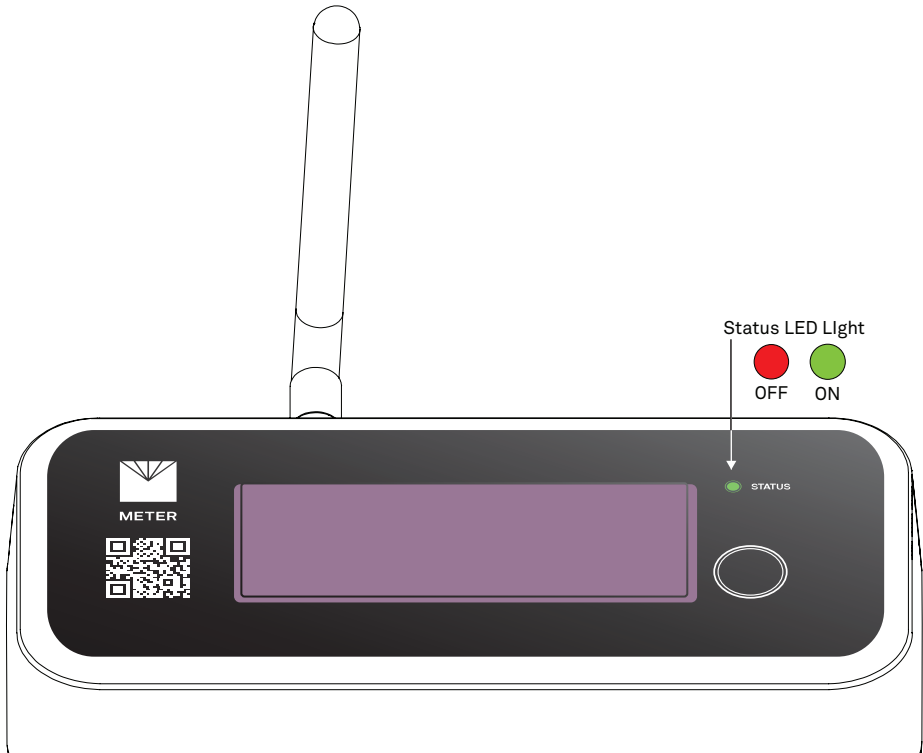

Figure 10 AROYA sensor nose—top view



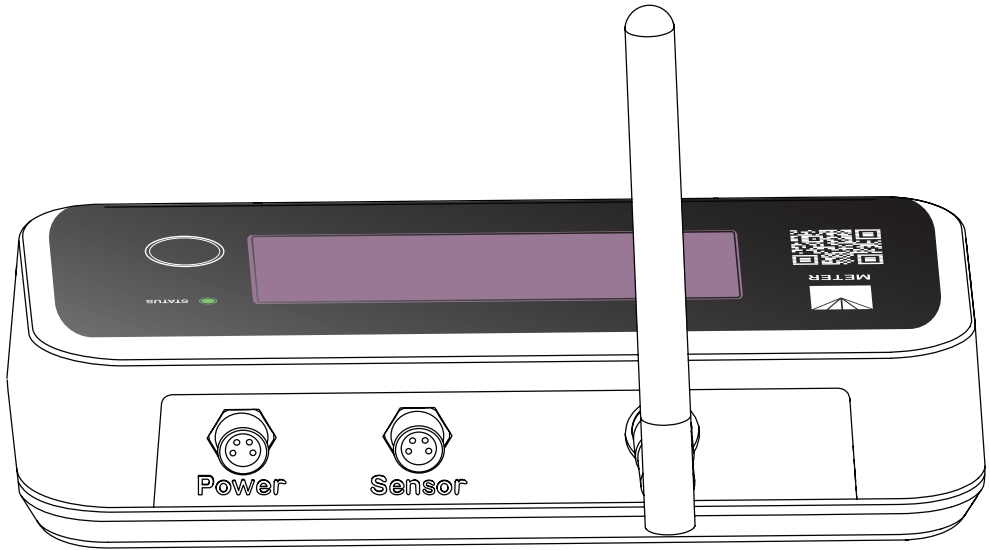

Figure 11 AROYA sensor nose—bottom view

## 4. SERVICE

This section describes the calibration and maintenance of the AROYA. Troubleshooting solutions and customer support information are also provided.

The AROYA Sensor Station, Sensor Nose, Repeater, and Climate Station, and Gateway should be returned to METER in the event that it quits working for any reason or if the battery no longer holds a charge.

Please refer to [Section 4.2](#) for instructions for returning the product to METER.

### 4.1 MAINTENANCE

AROYA hardware can be returned to METER in the need of maintenance. Refer to the RMA section or contact [Customer Support](#) for more information.

**NOTE:** The user should not and cannot perform any maintenance. The battery is not accessible.

### 4.2 REPAIRS

METER repairs manufacturer defects and instruments within the 1-year warranty at no charge. Repairs outside of the warranty window are charged based on cost of parts, labor, and shipping. An extra fee may be charged for rush work. Contact [Customer Support](#) for an estimated repair cost.

All AROYA units returning to METER for servicing must be accompanied with a Return Merchandise Authorization (RMA) number. Prior to shipping the instrument, contact [Customer Support](#) to obtain an RMA number.

1. Place the AROYA unit in a plastic bag to avoid disfiguring marks from the packaging.
2. Do not ship the power cord, serial cable, or any other accessories.
3. Ship the AROYA unit in its original box with suspension packaging.
4. If the original packaging is not available, use a box with at least 4 in of packing material (e.g., Styrofoam™ peanuts or bubble wrap) between the instrument and each wall of the box, ensuring the instrument is suspended in the packing material.
5. On the RMA form, please verify the ship to and bill to information, contact name, and problem description. If anything is incorrect, please contact [Customer Support](#).
6. Tape the box in both directions for added support.
7. Include the RMA number in the attention line on the shipping label.

## 4.3 TROUBLESHOOTING

Table 5 lists common problems and their solutions. If the problem is not listed or these solutions do not solve the issue, contact [Customer Support](#).

**Table 5 Troubleshooting**

Problem	Possible Solutions
Sensor is not reporting data	<b>GATEWAY</b>
	Check that the device is powered on by observing the red light is on. Confirm internet connectivity through the orange flashing light.
	<b>REPEATER and CLIMATE STATION</b>
	Check that the device is powered on (solid red light).
	<b>SENSOR NOSE</b>
	Make sure that the STATUS light flashes green upon pressing the function button to indicate that the device is set on.
	If the STATUS light flashes red upon pressing function button, then the device is asleep. Press the function button until the light response flashes green.
	If problems with the device persist please reset the sensor hardware by holding the press pad button for more than 5 s and wait to confirm the light indicated reset for 5 s.

Please see [Figure 12](#) and [Figure 13](#) for troubleshooting flowchart options for the following problems: all devices offline , groups or floors of devices offline, single substrate offline, and single repeater offline.

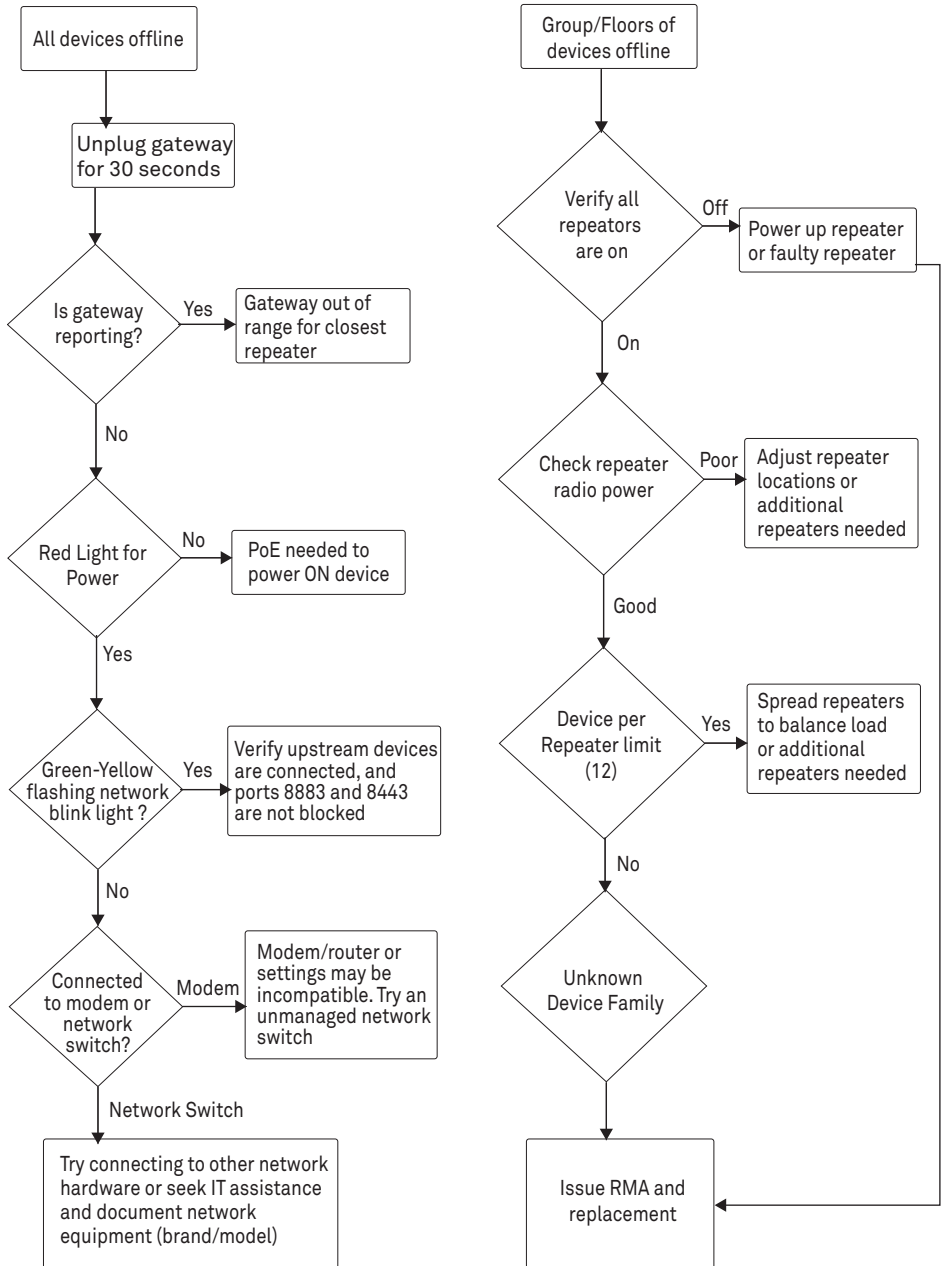

Figure 12 System Diagnostics Flowchart A

SERVICE

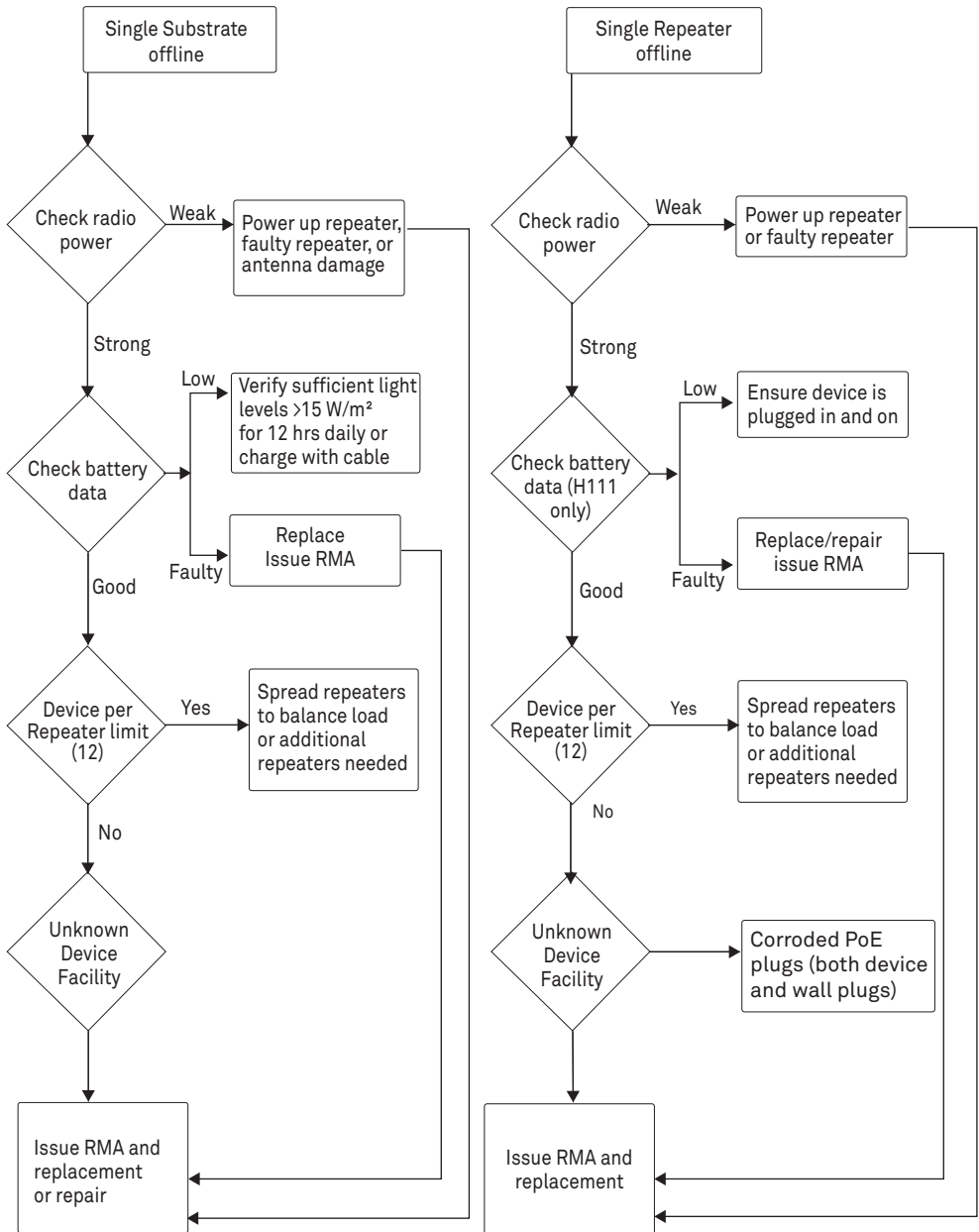

Figure 13 System Diagnostic Flowchart B

## 4.4 CUSTOMER SUPPORT

### NORTH AMERICA

Customer service representatives are available for questions, problems, or feedback Monday through Friday, 7:00 am to 5:00 pm Pacific time.

Email:        [support.roya@metergroup.com](mailto:support.roya@metergroup.com)  
                  [sales.roya@metergroup.com](mailto:sales.roya@metergroup.com)

Phone:        +1.509.332.2756

Fax:            +1.509.332.5158

Website:     [metergroup.com](http://metergroup.com)

If contacting METER by email, please include the following information:

Name	Email address
Address	Instrument serial number
Phone	Description of the problem

**NOTE:** For products purchased through a distributor, please contact the distributor directly for assistance.

## 4.5 TERMS AND CONDITIONS

By using METER instruments and documentation, you agree to abide by the METER Group, Inc. Terms and Conditions. Please refer to [metergroup.com/terms-conditions](http://metergroup.com/terms-conditions) for details.

# APPENDIX A. COMPLIANCE CERTIFICATIONS

## A.1 USA

### CAUTION

This marking indicates that the user should read all included documentation before use. Users of this product are cautioned to use accessories and peripherals approved by METER Group, Inc. The use of accessories other than those recommended, or changes to this product that are not approved by METER Group, may void the compliance of this product and may result in the loss of the user's authority to operate the equipment.

### CAUTION

If using a nonmanufacturer-supplied PoE device to power this system, ensure that the voltage rating does not exceed the recommended values stated above. The injector module used must comply with IEEE 802.3af and must be able to supply at least 24 W for the AROYA Repeater to function as intended.

## FCC § 15.19 LABELING REQUIREMENTS

If using a nonmanufacturer-supplied PoE device to power this system, ensure that the voltage rating does not exceed the recommended values stated above. The injector module used must comply with IEEE 802.3af and must be able to supply at least 24 W for the AROYA Repeater to function as intended.

1. This device may not cause harmful interference, and
2. This device must accept any interference received, including interference that may cause undesired operation.

## FCC § 15.21 INFORMATION TO USER

Changes or modification not expressly approved by the party responsible for compliance could void the user's authority to operate the equipment.

## FCC § 15.105 INFORMATION TO USER

This equipment has been tested and found to comply with the limits for a Class A digital device, pursuant to Part 15 of the FCC Rules. These limits are designed to provide reasonable protection against harmful interference when the equipment is operated in a commercial environment.

This equipment generates, uses, and can radiate radio frequency energy and, if not installed and used in accordance with the instruction manual, may cause harmful interference to radio communications. Operation of this equipment in a residential area is likely to cause harmful interference in which case the user will be required to correct the interference at his own expense.

## U.S.A. DIGITAL EMISSIONS COMPLIANCE

This equipment has been tested and found to comply with the limits for a Class A digital device, pursuant to Part 15 of the FCC Rules. These limits are designed to provide reasonable protection against harmful interference when the equipment is operated in a commercial environment. This equipment generates, uses, and can radiate radio frequency energy and, if not installed and used in accordance with the instruction manual, may cause harmful interference to radio communications. Operation of this equipment in a residential area is likely to cause harmful interference in which case the user will be required to correct the interference at his own expense.

## CANADIAN DIGITAL APPARATUS COMPLIANCE

This device complies with Industry Canada license-exempt RSS standards. Operation is subject to the following two conditions: (1) this device may not cause harmful interference, and (2) this device must accept any interference received, including interference that may cause undesired operation.

## CANADA CLASS A STATEMENT

This Class A digital apparatus meets all requirements of the Canadian Interference-Causing Equipment Regulations.

## RADIO PRECAUTION STATEMENT

Radio transmitters IC-5123A-MGM12P0, IC-25859-H110A00, and IC-25859-H310A00 have been approved by Innovation, Science, and Economic Development Canada to operate with the antenna types listed below, with the maximum permissible gain indicated. Antenna types not included in this list that have a gain greater than the maximum gain indicated for any type listed are strictly prohibited for use with this device.

Maximum Gain: 4.15 dBi, 50 ohm, Vertically polarized, dipole antenna.

## RADIO PRECAUTION STATEMENT

Radio transmitters IC-5123A-MGM12P0, IC-25859-H110A00, and IC-25859-H310A00 have been approved by Innovation, Science, and Economic Development Canada to operate with the antenna types listed below, with the maximum permissible gain indicated. Antenna types not included in this list that have a gain greater than the maximum gain indicated for any type listed are strictly prohibited for use with this device.

Maximum Gain: 4.15 dBi, 50 ohm, Vertically polarized, dipole antenna.

## 802.11 RADIO PRECAUTION STATEMENT

### CAUTION

Users are responsible for configuring the channels of operation that comply with their country's regulatory standards. A Wireless Network Administrator should review the operating restrictions detailed within the Access Point installation manual.

### CAUTION

See battery instructions. No user-serviceable parts. Charge only according to instructions in [Section 4.2](#). Use of incorrect charger may present a risk of fire or explosion.

## BATTERY RECYCLING INFORMATION



This product contains or uses a lithium-ion (Li-ion) main battery. When the battery reaches the end of its useful life (no longer holds a charge), the user should return the Sensor Nose, Repeater, or Climate Station to METER Group, Inc. Do not mix this battery with the solid waste stream. Contact Customer Support for return information.



## A.2 CANADA

### CAUTION

This marking indicates that the user should read all included documentation before use. Users of this product are cautioned to use accessories and peripherals approved by METER Group, Inc. The use of accessories other than those recommended, or changes to this product that are not approved by METER Group, may void the compliance of this product and may result in the loss of the user's authority to operate the equipment.

### MISE EN GARDE

ce marquage indique que l'utilisateur doit, avant l'utilisation, lire toute la documentation incluse. Les utilisateurs de ce produit sont avisés d'utiliser des accessoires et des périphériques approuvés par METER Group Inc. L'utilisation d'accessoires autres que ceux recommandés ou des changements à ce produit qui ne sont pas approuvés par Meter Group, peuvent annuler la conformité de ce produit et mettre fin au droit de l'utilisateur d'utiliser l'équipement.

---

### CAUTION

If using a nonmanufacturer-supplied PoE device to power this system, ensure that the voltage rating does not exceed the recommended values stated above. The injector module used must comply with IEEE 802.3af and must be able to supply at least 24 W for the AROYA Repeater to function as intended.

### CAUTION

si vous utilisez un dispositif PoE non fourni par le fabricant pour alimenter ce système, assurez-vous que la tension nominale ne dépasse pas les valeurs recommandées ci-dessus. Le module d'injection utilisé doit être conforme à la norme IEEE 802.3af et doit être en mesure de fournir au moins 24 W pour que le routeur AROYA fonctionne comme prévu.

---

## FCC § 15.19 LABELING REQUIREMENTS

If using a nonmanufacturer-supplied PoE device to power this system, ensure that the voltage rating does not exceed the recommended values stated above. The injector module used must comply with IEEE 802.3af and must be able to supply at least 24 W for the AROYA Repeater to function as intended.

1. This device may not cause harmful interference, and
2. This device must accept any interference received, including interference that may cause undesired operation.

## FCC § 15.19 LABELING REQUIREMENTS

Cet appareil est conforme à la partie 15 des règles de la FCC et aux normes RSS exemptes de licence d'Industrie Canada. Son fonctionnement est soumis aux deux conditions suivantes.

1. Cet appareil ne doit pas provoquer d'interférences nuisibles, et
  2. Cet appareil doit accepter toute interférence reçue, y compris les interférences pouvant entraîner un fonctionnement indésirable.
-

---

## FCC § 15.21 INFORMATION TO USER

Changes or modification not expressly approved by the party responsible for compliance could void the user's authority to operate the equipment.

## FCC § 15.21 INFORMATION TO USER

Les changements ou modifications non expressément approuvés par la partie responsable de la conformité peuvent annuler le droit de l'utilisateur à utiliser l'équipement.

---

## FCC § 15.105 INFORMATION TO USER

This equipment has been tested and found to comply with the limits for a Class A digital device, pursuant to Part 15 of the FCC Rules. These limits are designed to provide reasonable protection against harmful interference when the equipment is operated in a commercial environment.

This equipment generates, uses, and can radiate radio frequency energy and, if not installed and used in accordance with the instruction manual, may cause harmful interference to radio communications. Operation of this equipment in a residential area is likely to cause harmful interference in which case the user will be required to correct the interference at his own expense.

## FCC § 15.105 INFORMATION À L'UTILISATEUR

Cet équipement a été testé et déclaré conforme aux limites d'un appareil numérique de classe A, conformément à la partie 15 des règles de la FCC. Ces limites sont conçues pour fournir une protection raisonnable contre les interférences nuisibles lorsque l'équipement est utilisé dans un environnement commercial.

Cet équipement génère, utilise et peut émettre de l'énergie de radiofréquence et, s'il n'est pas installé et utilisé conformément au manuel d'instructions, peut provoquer des interférences nuisibles aux communications radio. Le fonctionnement de cet équipement dans une zone résidentielle est susceptible de provoquer des interférences nuisibles, auquel cas l'utilisateur devra corriger les interférences à ses propres frais.

---

## U.S.A. DIGITAL EMISSIONS COMPLIANCE

This equipment has been tested and found to comply with the limits for a Class A digital device, pursuant to Part 15 of the FCC Rules. These limits are designed to provide reasonable protection against harmful interference when the equipment is operated in a commercial environment. This equipment generates, uses, and can radiate radio frequency energy and, if not installed and used in accordance with the instruction manual, may cause harmful interference to radio communications. Operation of this equipment in a residential area is likely to cause harmful interference in which case the user will be required to correct the interference at his own expense.

## CONFORMITÉ AUX ÉMISSIONS NUMÉRIQUES AUX ÉTATS-UNIS

Cet équipement a été testé et déclaré conforme aux limites d'un appareil numérique de classe A, conformément à la partie 15 des règles de la FCC. Ces limites sont conçues pour fournir une protection raisonnable contre les interférences nuisibles lorsque l'équipement est utilisé dans un environnement commercial. Cet équipement génère, utilise et peut émettre de l'énergie de radiofréquence et, s'il n'est pas installé et utilisé conformément au manuel d'instructions, peut provoquer des interférences nuisibles aux communications radio. Le fonctionnement de cet équipement dans une zone résidentielle est susceptible de provoquer des interférences nuisibles, auquel cas l'utilisateur devra corriger les interférences à ses propres frais.

---

---

## CANADIAN DIGITAL APPARATUS COMPLIANCE

This device complies with Industry Canada license-exempt RSS standards. Operation is subject to the following two conditions: (1) this device may not cause harmful interference, and (2) this device must accept any interference received, including interference that may cause undesired operation.

## CONFORMITÉ DES APPAREILS NUMÉRIQUES AU CANADA

Le présent appareil est conforme aux CNR d'Industrie Canada applicables aux appareils radio exempts de licence. L'exploitation est autorisée aux deux conditions suivantes : 1) l'appareil ne doit pas produire d'interférences nuisibles, et 2) l'appareil doit accepter toute interférence reçue, y compris les interférences pouvant entraîner un fonctionnement indésirable.

---

## CANADA CLASS A STATEMENT

This Class A digital apparatus meets all requirements of the Canadian Interference-Causing Equipment Regulations.

## DÉCLARATION CLASSE A DU CANADA

Cet appareil numérique de la Classe A est conforme à toutes les exigences du Règlement canadien sur les équipements causant des interférences.

---

## RADIO PRECAUTION STATEMENT

Radio transmitters IC-5123A-MGM12P0, IC-25859-H110A00, and IC-25859-H310A00 have been approved by Innovation, Science, and Economic Development Canada to operate with the antenna types listed below, with the maximum permissible gain indicated. Antenna types not included in this list that have a gain greater than the maximum gain indicated for any type listed are strictly prohibited for use with this device.

Maximum Gain: 4.15 dBi, 50 ohm, Vertically polarized, dipole antenna.

## DÉCLARATION DE PRÉCAUTION RADIO

Les émetteurs radio IC-5123A-MGM12P0, IC-25859-H110A00, IC-25859-H110A00, IC-25859-H310A00 et IC-25859-H311A00 ont été approuvés par Innovation, Science et Développement économique Canada pour fonctionner avec les types d'antennes répertoriés ci-dessous, avec le gain maximum autorisé indiqué. Les types d'antennes non inclus dans cette liste qui ont un gain supérieur au gain maximal indiqué pour tout type répertorié sont strictement interdits pour utilisation avec cet appareil.

Gain maximal : 4,15 dBi, 50 ohms, antenne dipôle polarisée verticalement.

---

---

## 802.11 RADIO PRECAUTION STATEMENT

### CAUTION

Users are responsible for configuring the channels of operation that comply with their country's regulatory standards. A Wireless Network Administrator should review the operating restrictions detailed within the Access Point installation manual.

### CAUTION

See battery instructions. No user-serviceable parts. Charge only according to instructions in [Section 4.2](#). Use of incorrect charger may present a risk of fire or explosion.

## DÉCLARATION DE PRÉCAUTION RADIO 802.11

### CAUTION

les utilisateurs sont responsables de la configuration des canaux de fonctionnement conformes aux normes réglementaires de leur pays. Un administrateur de réseau sans fil doit examiner les restrictions d'exploitation détaillées dans le manuel d'installation du point d'accès.

### CAUTION

Voir les instructions de la batterie. Aucune pièce réparable par l'utilisateur. Chargez uniquement conformément aux instructions de la section 4.2. L'utilisation d'un chargeur incorrect peut présenter un risque d'incendie ou d'explosion.

---

## BATTERY RECYCLING INFORMATION



This product contains or uses a lithium-ion (Li-ion) main battery. When the battery reaches the end of its useful life (no longer holds a charge), the user should return the Sensor Nose, Repeater, or Climate Station to METER Group, Inc. Do not mix this battery with the solid waste stream. Contact Customer Support for return information.

### **⚠ CAUTION**

See battery instructions. No user-serviceable parts. Charge only according to instructions in [Section 4.2](#). Use of incorrect charger may present a risk of fire or explosion.

## INFORMATIONS SUR LE RECYCLAGE DE LA BATTERIE

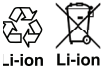

Ce produit contient ou utilise une batterie principale au lithium-ion (Li-ion). Lorsque la batterie atteint la fin de sa durée de vie (ne tient plus la charge), l'utilisateur doit renvoyer la station du capteur, le nez du capteur, le routeur ou le routeur de climat à METER Group, Inc. Ne mélangez pas cette batterie avec le flux de déchets solides. Contactez le service client pour obtenir des informations de retour.

### **⚠ CAUTION**

Consultez les instructions de la batterie. Aucune pièce réparable par l'utilisateur. Chargez uniquement conformément aux instructions de la [section 7.2](#). L'utilisation d'un chargeur incorrect peut présenter un risque d'incendie ou d'explosion.