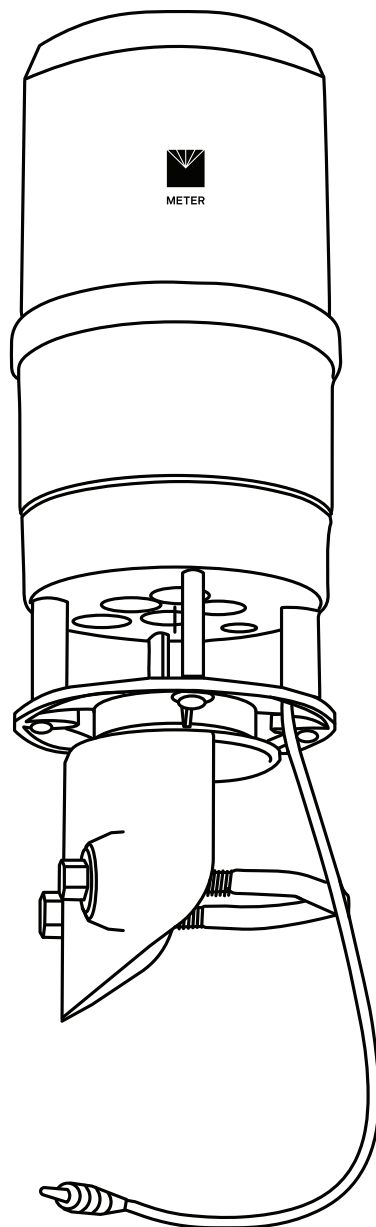

TABLE OF CONTENTS

1. Introduction	1
2. Operation	3
2.1 Installation	3
2.2 Connecting.....	6
2.2.1 Connect to METER Logger	7
2.2.2 Connect to Non-METER Logger	8
2.3 Communication	10
2.3.1 SDI-12.....	10
2.3.2 Modbus RS-485	11
3. System	12
3.1 Specifications.....	12
3.2 Solar Radiation (Pyranometer).....	18
3.3 Wind speed and direction (Anemometer)	19
3.3.1 Wind Speed and Direction Theory	20
3.4 Vapor Pressure/Relative Humidity Sensor	22
3.5 Precipitation	23
3.5.1 Remove Rain Funnel.....	25
3.5.2 Electrical Conductivity (EC)	29
3.6 Temperature Sensor.....	29
3.6.1 Air Temperature Theory.....	30
3.7 Lightning Sensor	31
3.8 Barometric Pressure Sensor	32
3.9 Tilt Sensor.....	32
3.10 Limitations.....	32

3.10.1 Snow and Ice Accumulation	32
3.10.2 Heavy Rain and Strong Wind	33
3.10.3 Electromagnetic Interference	33
4. Service.....	34
4.1 Calibration	34
4.2 Recalibration Recommendations.....	35
4.3 Cleaning and Maintenance.....	36
4.4 Update Firmware	38
4.5 Troubleshooting.....	38
4.6 Customer Support.....	40
4.7 Terms and Conditions	40
References	41
Index	42
APPENDIX A. Compliance Certifications.....	44
A.1 USA.....	44
A.2 European Union	45

ATMOS 41 GEN 2



ATMOS 41 GEN 2

This device has been evaluated and shown compliant with the IC RF Exposure limits under mobile exposure conditions (antennas are greater than 20cm from a person's body).

Avis d'Industrie Canada (IC)

Cet appareil numérique de classe B est conforme aux normes canadiennes CAN ICES-3(B) / NMB- 3(B) et RSS-210.

Son fonctionnement est soumis aux deux conditions suivantes:

- cet appareil ne doit pas causer d'interférence
- cet appareil doit accepter toute interférence, notamment les interférences qui peuvent affecter son fonctionnement

Informations concernant l'exposition aux fréquences radio (RF)

Ce périphérique a été évalué et démontré conforme aux limites d'exposition aux fréquences radio (RF) d'IC lorsqu'il est installé dans des produits hôtes particuliers qui fonctionnent dans des conditions d'exposition à des appareils mobiles (les antennes se situent à plus de 20 centimètres du corps d'une personne).

Changes or modifications to the EM60 series loggers not expressly approved by METER Group, Inc. could void Industry Canada (IC) compliance and thus the user's authority to operate the equipment.

Table A.1

A.2 EUROPEAN UNION

R&TTEd and European Conformance CE mark

Radiofrequency radiation exposure Information: this equipment complies with radiation exposure limits prescribed for an uncontrolled environment for fixed and mobile use conditions. This equipment should be installed and operated with a minimum distance of 20 cm between the radiator and the body of the user or nearby persons. This transmitter must not be co-located or operating in conjunction with any other antenna or transmitter except as authorized in the certification of the product.

A full CE declaration of conformity for the EM60 is available on request from METER Group.

APPENDIX A. COMPLIANCE CERTIFICATIONS

This appendix contains compliance statements that apply to the EM60 and EM60G.

A.1 USA

The following FCC statement applies to the EM60 and EM60G. This device complies with Part 15 of the FCC Rules. Operation is subject to the following conditions:

1. This device may not cause harmful interference.
2. This device must accept any interference received, including interference that may cause undesired operation.

The EM60 series loggers contain one or more of the following radio modules, listed by their FCC identification numbers:

- SH6MDBT40 (all EM60 series)
- XPYLISAU201 or XPYLISAU200 (EM60G only)

Changes or modifications to the EM60 series loggers not expressly approved by METER Group, Inc. could void FCC compliance and thus the user's authority to operate the equipment.

This equipment has been tested and found to comply with the limits for a Class B digital device, pursuant to Part 15 of the FCC Rules. These limits are designed to provide reasonable protection against harmful interference in a residential installation. This equipment generates, uses, and can radiate radio frequency energy and, if not installed and used in accordance with the instructions, may cause harmful interference to radio communications.

There is no guarantee that a particular installation will not cause any interference. If this equipment does cause harmful interference to radio or television reception, which can be determined by turning the equipment off and on, METER encourage users to attempt to correct the interference by trying one or more of the following measures:

- Reorient or relocate the receiving antenna
- Increase the separation between the equipment and receiver
- Consult [Customer Support](#)

Canada

Industry Canada (IC) Notices

This Class B digital apparatus complies with Canadian CAN ICES-3(B) / NMB-3(B) and RSS-210. Operation is subject to the following two conditions:

- this device may not cause interference
- this device must accept any interference, including interference that may cause undesired operation of the device

The EM60 series loggers contain one or more of the following radio modules, listed by their IC identification numbers:

- 8017A-MDBT40 (all EM60 series)
- 8595A-LISAU201 or 8595A-LISAU200N (EM60G only)

Radio Frequency (RF) Exposure Information

1. INTRODUCTION

Thank you for choosing the ATMOS 41 Gen 2 All-in-One Weather Station from METER Group.

The ATMOS 41 Gen 2 All-in-One Weather Station is designed for continuous monitoring of environmental variables, including all standard weather measurements (Section 3). The ATMOS 41 Gen 2 measures the following:

- Solar radiation
- Precipitation
- Precipitation electrical conductivity
- Air temperature
- Barometric pressure
- Vapor pressure
- Relative humidity
- Wind speed
- Wind direction
- Maximum wind gust
- Lightning strikes
- Lightning distance
- Tilt

All sensors are integrated into a single, small form-factor unit, requiring minimal installation effort. A robust design that prevents errors because of wear or fouling make the weather station ideal for long-term, remote installations. ATMOS 41 Gen 2 can be used for a variety of applications:

- Weather monitoring
- Microenvironment monitoring
- Spatially-distributed environmental monitoring
- Crop weather monitoring
- Fire danger monitoring
- Weather networks
- Renewable energy

INTRODUCTION

Additional advantages include its low-power design that supports battery-operated data loggers with an SDI-12 three-wire interface, and certain models being Modbus RS-485 enabled. A tilt sensor warns the user of out-of-level condition, and no configurations are necessary.

Prior to use, verify all ATMOS 41 Gen 2 system components are included and appear in good condition.

ATMOS 41 GEN 2

troubleshooting **38–40**

V

vapor pressure sensor **36**

Z

ZENTRA

logger **7**

ZENTRA Cloud **7**

ZENTRA Utility **7**

INDEX

B

barometric pressure sensor 32, 36

C

calibration

frequency 35

initial 34–35

cleaning 36–38

compliance

CE 45

FCC 44

IC 44–45

connecting 6–10

customer support 40

D

data acquisition system 15. See also installation, connecting the ATMOS 41

E

email address 40

F

fax number 40

I

installation

tools required 3

L

limitations 32–34

M

maintenance 36–38

measurements

air temperature 13, 34

barometric pressure 14, 32, 35

humidity sensor temperature 13

lightning distance 14, 35

lightning strike 14, 35

precipitation/rainfall 12, 32–33, 34

relative humidity 12, 34

solar radiation 12, 34

tilt 14, 35

vapor pressure 12, 34

wind direction 14, 35

wind gust 14

wind speed 14, 35

measurement specifications.

See specifications, measurement specifications

Modbus 42

P

phone number 40

Precipitation 23

pyrometer 36

R

references 41

relative humidity sensor 36

S

specifications

cable length 15

communication 15

data logger compatibility 15

dimensions 15

physical 15

T

terms and conditions 40

theory

lightning 31

wind 20–22

tipping spoon 42

2. OPERATION

Please read all instructions before operating the ATMOS 41 Gen 2 to ensure it performs to its full potential

⚠ PRECAUTION

METER sensors are built to the highest standards, but misuse, improper protection, or improper installation may damage the sensor and possibly void the manufacturer's warranty. Before integrating ATMOS 41 Gen 2 into a system, make sure to follow the recommended installation instructions and have the proper protections in place to safeguard sensors from damage.

2.1 INSTALLATION

Follow the steps listed in Table 1 to set up the ATMOS 41 Gen 2 and start collecting data.

Table 1 Installation

Tools Needed	<p>Wrench 13 mm (1/2in)</p> <p>Mounting pole 31.8 to 50.8 mm (1.25 to 2.0 in) diameter</p> <p>NOTE: Smaller mounts are compatible if washers are added to the V bolt (not included). United States standard pipe sizes that are compatible are 1.00-, 1.25-, and 1.50-in. Square tubing with a width of 1.25 to 2.00 or T-posts can also work as mounting options.</p>
Field site considerations	<p>Identify Mounting Location—Landscape</p> <p>Choose the desired location based on relevant details, including vegetation cover throughout the season, solar exposure, and wildlife and livestock activity.</p> <div data-bbox="2169 1044 2480 1336" style="text-align: center;"> <p>Low vegetation < 10 cm</p> </div> <p>If adhering to World Meteorological Organization (WMO)^a siting standards, make sure the mount location has minimal slope and low vegetation height so the pyranometer found on top of the rain funnel will not be covered by shade.</p>

OPERATION

Table 1 Installation (continued)

Identify Mounting Location—Interferences

Consider a site far from sources of high electromagnetic interference (EMI), such as high-voltage power transmission lines, metallic objects, sources of heat, bodies of water, and obstructions. EMI sources could adversely affect ATMOS 41Gen 2 rainfall measurements.

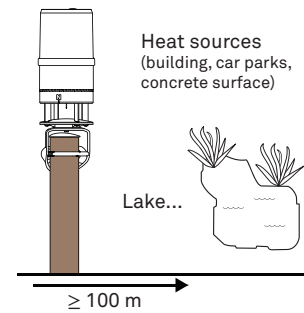

Field site considerations (continued)

WMO siting standards recommend siting 100 m away from heat sources and bodies of water.

Conduct System Check

Plug the weather station into the logger (Section 2.2.1).

Verify all sensors are functional and read within expected ranges.

Install Mounting Pole

Use a mounting pole with a 31.8- to 50.8-mm (1.25- to 2.0-in) diameter.

Prepare the mounting pole to the appropriate height. Many installations require the ATMOS 41 Gen 2 to be mounted 2 m above ground, but mounting height can be adjusted based on the specific application.

The mounting pole should be within 4.5° of level.

REFERENCES

REFERENCES

Campbell, Gaylon S. and Michael H. Unsworth. 1979. An Inexpensive Sonic Anemometer for Eddy Correlation. *Journal of Applied Meteorology*. 18 (8):1072–1077.

Buck, Arden L. 1981. New Equations for Computing Vapor Pressure and Enhancement Factor. *Journal of Applied Meteorology*. 20 (12):1527–1432.

Robinson, R.A. and Stokes, R.H. 1970. *Electrolyte Solutions*. 2nd ed. New York: Dover Publications.

4.6 CUSTOMER SUPPORT

NORTH AMERICA

Customer service representatives are available for questions, problems, or feedback Monday through Friday, 7:00 am to 5:00 pm Pacific time.

Email: support.environment@metergroup.com
sales.environment@metergroup.com

Phone: +1.509.332.5600

Fax: +1.509.332.5158

Website: metergroup.com

EUROPE

Customer service representatives are available for questions, problems, or feedback Monday through Friday, 8:00 to 17:00 Central European time.

Email: support.europe@metergroup.com
sales.europe@metergroup.com

Phone: +49 89 12 66 52 0

Fax: +49 89 12 66 52 20

Website: metergroup.de

If contacting METER by email, please include the following information:

Name	Email address
Address	Instrument serial number
Phone	Description of the problem

NOTE: For products purchased through a distributor, please contact the distributor directly for assistance.

4.7 TERMS AND CONDITIONS

By using METER instruments and documentation, you agree to abide by the METER Group, Terms and Conditions. Please refer to metergroup.com/terms-conditions for details.

Table 1 Installation (continued)

Field Installation

Mount Toward True North

Place the top of the mounting post under the mounting shelf in the mounting bracket.

Orient the **N** engraved on the side of the instrument to point true north (not magnetic north). The ATMOS 41 Gen 2 must be oriented correctly by hand for accurate wind direction measurements.

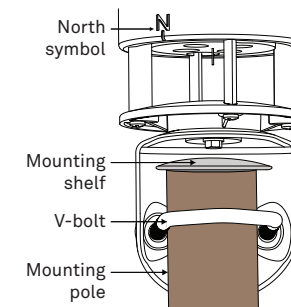

Mounting

Mount and Secure Device

Tighten the V-bolt nuts by hand until hand-tight. Then tighten the nuts further with the 13-mm end of the wrench included. Secure the ATMOS 41 Gen 2 flat and tight against the top of the mounting pole.

⚠ CAUTION

Do not overtighten the bolt.

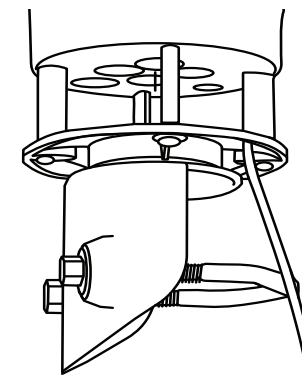

Table 1 Installation (continued)

Mounting (continued)	<p>Level the Device Use the bubble level underneath the ATMOS 41 Gen 2 to level the weather station. The weather station angle can be adjusted by (1) loosening the leveling screw attached to the bottom with the 8-mm end of the wrench (included), (2) moving the weather station side to side as needed to level, and then retightening the screw.</p> <p>The ATMOS 41 Gen 2 must be within approximately $\pm 2^\circ$ of dead level to accurately measure rainfall and solar radiation.</p>
	<p>Secure and Protect Cables NOTE: Improperly protected cables can lead to severed cables or disconnected sensors. Cabling issues can be caused by many factors such as rodent damage, driving over sensor cables, tripping over cables, not leaving enough cable slack during installation, or poor sensor wiring connections.</p> <p>Install cables in conduit or plastic cladding when near the ground to avoid rodent damage.</p> <p>Gather and secure cables between the ATMOS 41 Gen 2 and the data logger to the mounting mast in one or more places.</p>
	<p>Connect to Data Logger Plug the sensor into a data logger.</p> <p>Use the data logger to make sure the sensor is reading properly.</p> <p>Verify these readings are within expected ranges.</p> <p>For more instructions on connecting to data loggers, refer to Section 2.2.</p>

2.2 CONNECTING

The ATMOS 41 Gen 2 works seamlessly with METER data loggers. The ATMOS 41 Gen 2 can also be used with other data loggers, such as those from Campbell Scientific, Inc.

ATMOS 41 Gen 2s using SDI-12 communication require an excitation voltage in the range of 3.6 to 15.0 VDC and operates at a 2.8- to 5.5-VDC level for data communication.

ATMOS 41 Gen 2 sensors using SDI-12 communication come with a 3.5-mm stereo plug connector ([Figure 1](#)) to facilitate easy connection with METER loggers. ATMOS 41 Gen 2 sensors may be ordered with stripped and tinned wires to facilitate connecting to some third-party loggers ([Section 2.2.2](#)).

To use a Modbus RS-485 protocol, please verify your ATMOS 41 Gen 2 is Modbus RS-485 enabled by checking the serial number of your unit found on a white label on the cable and on a sticker underneath the precipitation funnel (see [Section 3.5.1](#) for how to remove your funnel). SDI-12 only units have serial numbers in the format of A41G2S1234567,

Table 4 Troubleshooting the ATMOS 41 Gen 2 (continued)

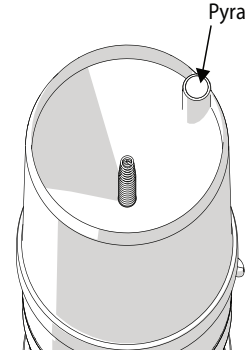
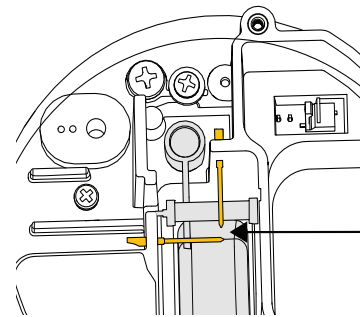
Problem	Possible Solutions
<p>Not reading any rain or not measuring rain accurately</p>	<p>Remove any debris from rain gauge funnel. The ATMOS 41 Gen 2 must be within approximately ± 2 degrees of dead level to accurately measure rainfall. If not within this range, drops from the flared hole can miss the gold electrodes entirely. Use the internal level measurements that are available in the ATMOS 41 Gen 2 data stream to confirm that the ATMOS 41 Gen 2 is level.</p> <p>Gently twist the top of the weather station and remove the rain gauge funnel.</p> <p>NOTE: BE CAREFUL TO UNPLUG THE PYRANOMETER CONNECTOR INSIDE THE FUNNEL BEFORE REMOVING THE FUNNEL COMPLETELY.</p> <p>Check to make sure that there are no obvious problems and that the gold electrodes are aligned correctly Figure 24.</p> <div style="display: flex; justify-content: space-around; align-items: center;"> <div style="text-align: center;">  <p>Figure 23 Pyranometer</p> </div> <div style="text-align: center;">  <p>Figure 24 Gold electrodes</p> </div> </div> <p>The accuracy of the rain gauge measurement can be checked using the procedure described in How to check the drip counter calibration (metergroup.com/atmos-41-drip-counter-calibration).</p>
<p>No temperature reading</p>	<p>Check the temperature needle to be sure it is not pushed in (pushing in the temperature sensor will break the thermistor wires and stop measurement).</p> <p>Do not abuse the temperature sensor needle when cleaning, because its very delicate lead wires can be easily damaged.</p>
<p>No pyranometer reading</p>	<p>Carefully remove the rain funnel as described in Section 3.5.</p> <p>NOTE: BE CAREFUL TO UNPLUG THE PYRANOMETER CONNECTOR INSIDE THE FUNNEL BEFORE FULLY REMOVING THE FUNNEL.</p> <p>Make sure the pyranometer plug (Figure 23) is plugged in.</p> <p>If the pyranometer connected is accidentally damaged, contact Customer Support.</p>

4.4 UPDATE FIRMWARE

METER will occasionally release firmware updates that improve ATMOS 41 Gen 2 performance. Please consult with [Customer Support](#) about the necessity or process of updating firmware on ATMOS 41 Gen 2.

4.5 TROUBLESHOOTING

Table 4 Troubleshooting the ATMOS 41 Gen 2

Problem	Possible Solutions
ATMOS 41 Gen 2 not responding	Check power to the sensor.
	Check sensor cable and stereo plug connector integrity.
	Try a different port on the data logger.
	For SDI-12 version check data logger wiring to ensure the following connections: Brown—3.6- to 15.0-V power supply Orange—digital out Bare—ground
Water not flowing through rain gauge	Check spring, screen, and the outflow to ensure there is no lodged debris.
No wind speed	Check anemometer pathway to make sure there is no debris blocking the path of the ultrasonic transducer measurement (between transducers and convex base plate).
	Check the ultrasonic transducers for water build-up; if there is moisture, take a dry cloth and dab it away.
	Check to see that the convex base plate (Figure 7) is not dirty. Clean by flushing with water and dry with a dry cloth (Section 4.3).
	Be sure the ATMOS 41 Gen 2 is level.

while Modbus RS-485 enabled units have serial numbers formatted as A41G2M1234567. ATMOS 41 Gen 2s using Modbus RS-485 communication require an excitation voltage in the range of 4 to 24 VDC and operate at a 12 to -7 VDC level for data communication.

For extensive directions on how to integrate the sensor into third-party loggers, refer to the ATMOS 41 Gen 2 Integrator Guide to integrate into either SDI-12 or Modbus RS-485 data acquisition systems.

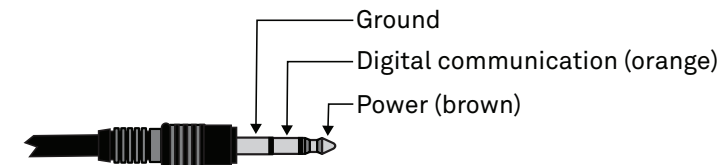

Figure 1 3.5-mm stereo plug connector wiring

The ATMOS 41 Gen 2 comes standard with a 5-m cable or a 1.5-m M12 connector. It may be purchased with custom cable lengths for an additional fee (on a per-meter basis). In some instances, the cable can be extended beyond 75 m by the user, but this is discouraged for a variety of reasons. Please contact [Customer Support](#) for more details before extending or splicing cables.

2.2.1 CONNECT TO METER LOGGER

The ATMOS 41 Gen 2 works most efficiently with ZENTRA series data loggers. Check the [METER downloads webpage](#) (meter.ly/software-downloads) for the most recent data logger firmware. Logger configuration may be done using either ZENTRA Utility (desktop and mobile application) or ZENTRA Cloud (web-based application for cell-enabled data loggers).

NOTE: This system will not work with legacy data loggers (Decagon Em5, Em5B, Em50, Em50R, and Em50G).

1. Plug the stereo plug connector into one of the sensor ports on the logger.
2. Use the appropriate software application to configure the chosen logger port for the ATMOS 41 Gen 2. METER data loggers will automatically recognize ATMOS 41 Gen 2 sensors.
3. Set the measurement interval.

METER data loggers measure the ATMOS 41 Gen 2 every minute and return the average of the 1-min data across the chosen measurement interval.

NOTE: The ATMOS 41 Gen 2 draws more current than most other METER sensors because it makes frequent wind speed and precipitation measurements. As a result, plugging multiple ATMOS 41 Gen 2 stations into a single ZENTRA or EM60 data logger may have significant impact on battery life. At times or in regions with plentiful sunshine, the solar panel should provide ample charge and this should not be an issue. During the winter or periods of extended heavy clouds, the solar panel may not provide enough charging current to keep the system running with multiple ATMOS 41 Gen 2 units. METER recommends using only one ATMOS 41 Gen 2 per ZENTRA or EM60 data logger.

OPERATION

ATMOS 41 Gen 2 data can be downloaded from METER data loggers using either ZENTRA Utility or ZENTRA Cloud. Refer to the logger user manual for more information about these programs.

2.2.2 CONNECT TO NON-METER LOGGER

The ATMOS 41 Gen 2 can be purchased for use with non-METER (third party) data loggers. Refer to the third-party logger manual for details on logger communications, power supply, and ground ports. The [ATMOS 41 Gen 2 Integrator Guide](#) also provides detailed instructions on connecting sensors to non-METER loggers.

ATMOS 41 Gen 2 sensors can be ordered with stripped and tinned (pigtail) wires for use with screw terminals. Refer to the third-party logger manual for details on wiring.

Connect the ATMOS 41 Gen 2 wires to the data logger as illustrated in [Figure 2](#) and [Figure 3](#), with the power supply wire (brown) connected to the excitation, the digital out wire (orange) to a digital input, and the bare ground wire to ground.

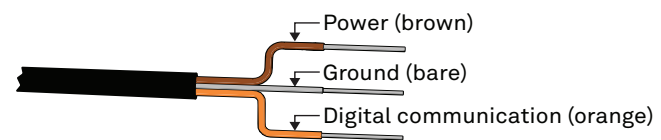

Figure 2 Pigtail wiring

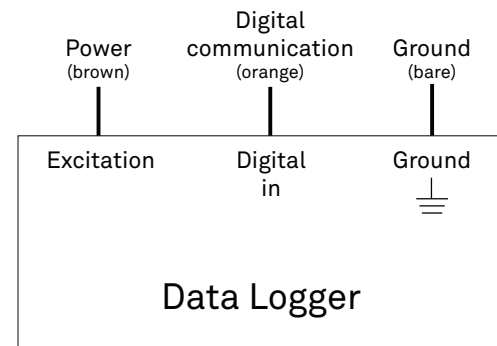

Figure 3 Three-wire SDI-12 wiring diagram

ATMOS 41 GEN 2

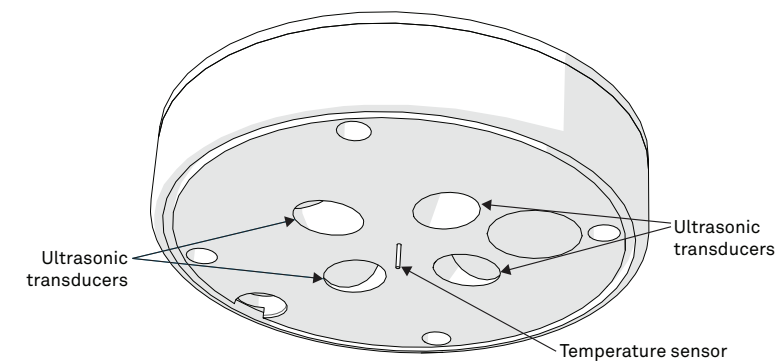

Figure 19 Temperature needle and ultrasonic transducers

NOTE: Do not allow water to enter the ultrasonic sensors ([Figure 19](#)). Water may corrode the metal parts inside the sensors and ruin them. Do not touch the temperature sensor when cleaning because it is very delicate and can be damaged if pushed into the ATMOS 41 body.

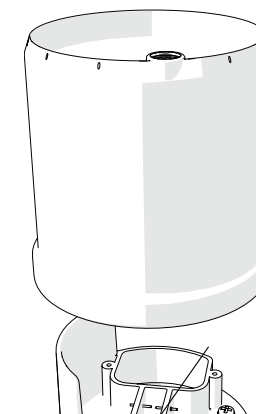

Figure 20 Downspout

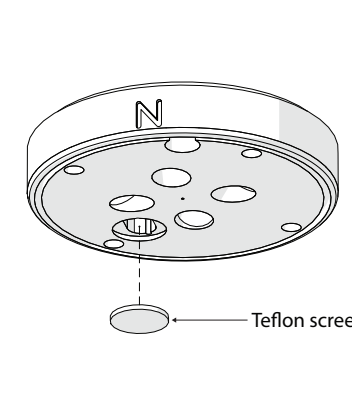

Figure 21 Teflon screen

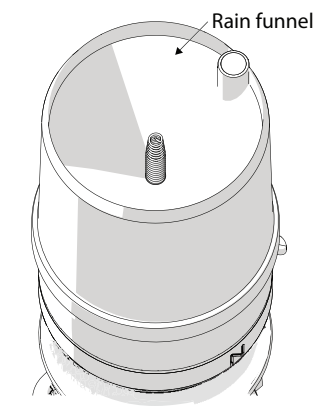

Figure 22 Rain funnel and pyranometer

For instructions on replacing the funnel, follow meter.ly/rain_funnel_replace.

SERVICE

- ^a Calibrated, field-swappable replacement pyranometers are available from METER. Contact [Customer Support](#) to purchase a new funnel and consult [Instructions for swapping ATMOS 41 Gen 2 funnel](https://meter.ly/rain_funnel_replace) (https://meter.ly/rain_funnel_replace) for instructions on field swapping the pyranometer.
- ^b ATMOS 41 Gen 2 barometric pressure and vapor pressure/RH sensors and their respective calibrations are housed on a module that sits behind the access door in the same housing as the ultrasonic transducers (Figure 8). This module is field-swappable, so sensors in need of calibration can be removed and replaced by a module with calibrated sensors. Please contact [Customer Support](#) for new sensor modules and consult [Instructions for swapping ATMOS 41 Gen 2 daughterboard](https://meter.ly/atmos41-swap-RH-daughterboard) (https://meter.ly/atmos41-swap-RH-daughterboard) for instructions on swapping the module.

4.3 CLEANING AND MAINTENANCE

For more information on thoroughly cleaning the ATMOS 41 Gen 2, see [ATMOS cleaning instructions](https://meter.ly/atmos-cleaning-instructions) (https://meter.ly/atmos-cleaning-instructions).

CAUTIONS

- **DO NOT** immerse the ATMOS 41 Gen 2 in water.

- **DO NOT** touch the temperature sensor needle (Figure 19).

NOTE: The temperature sensor needle lead wires are very delicate and can be easily damaged.

- Avoid more than light pressure on the ultrasonic transducers (Figure 19).

1. Be sure the sensor is level after cleaning.
2. Make sure nothing is obscuring the temperature sensor or the ultrasonic transducers shown in Figure 19 (cobwebs, leaves, wasp nests, etc.).
3. Check the following areas to make sure they are clear of miscellaneous environmental, animal (specifically bird droppings) and insect debris, or spider webs:
 - a. Rain funnel (Figure 22)
 - b. Pyranometer (Figure 22)
 - c. Ultrasonic transducer openings (Figure 19)
 - d. Sintered glass reflection plate (Figure 10)
4. Clean the ATMOS 41 body.
 - a. Scrub with light to medium pressure using a warm, damp cloth.
 - b. Clean around posts and between crevices using a dry brush.
 - c. Check the downspout (Figure 20) for debris.
 - d. Observe the Teflon screen (Figure 21) to see if it is dirty.
If the screen is dirty, it is best to replace it. Contact [Customer Support](#) for a replacement Teflon screen.

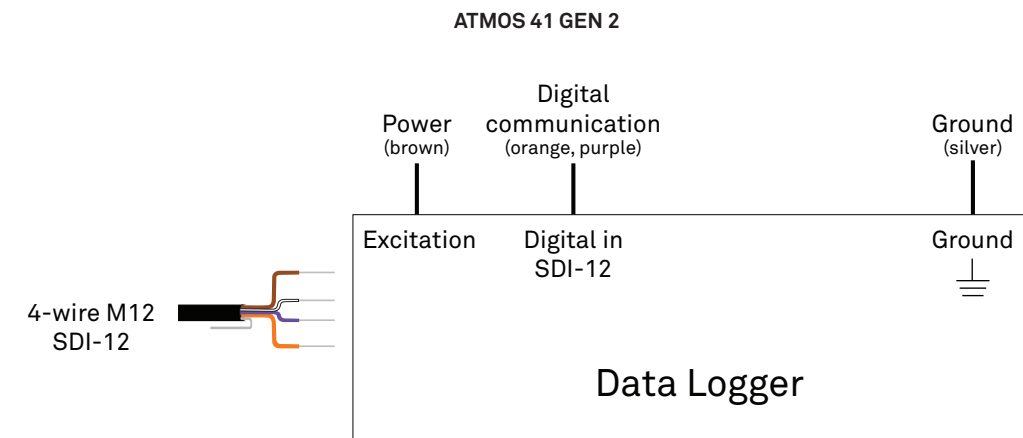

Figure 4 Four-wire M12 connector SDI-12 wiring diagram

NOTE: The acceptable range of excitation voltages is from 3.6 to 15.0 VDC. To read the ATMOS 41 Gen 2 with Campbell Scientific data loggers, power the sensors off a 12-V port.

If the ATMOS 41 Gen 2 cable has a standard stereo plug connector and needs to be connected to a non-METER data logger, use one of the following two options.

Option 1

1. Clip off the stereo plug connector on the sensor cable.
2. Strip and tin the wires.
3. Wire it directly into the data logger.

This option has the advantage of creating a direct connection and minimizes the chance of the sensor becoming unplugged. However, it then cannot be easily used in the future with a METER readout unit or data logger.

Option 2

Obtain an adapter cable from METER.

The adapter cable has a connector for the stereo plug connector on one end and three wires (or pigtail adapter) for connection to a data logger on the other end. The stripped and tinned adapter cable wires have the same termination as in Figure 2: the brown wire is excitation, the orange is output, and the bare wire is ground.

NOTE: Secure the stereo plug connector to the pigtail adapter connections using adhesive-lined heat shrink to ensure the sensor does not become disconnected during use.

For RS-485, the power supply wire (brown) will be connected to the excitation, the digital communication + wire (white) to a digital input (high), the digital communication - wire (black) to a digital input (low) and the blue ground wire to ground. For SDI-12, both the digital communication - and ground wires will be connected to ground.

OPERATION

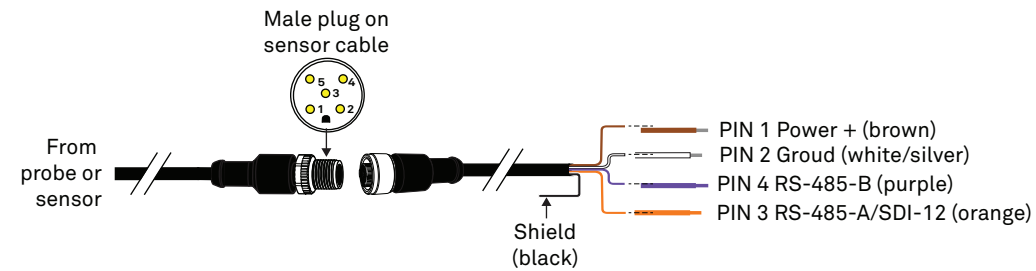

Figure 5 Four-wire M12 connector and pigtail adapter for use with screw terminals

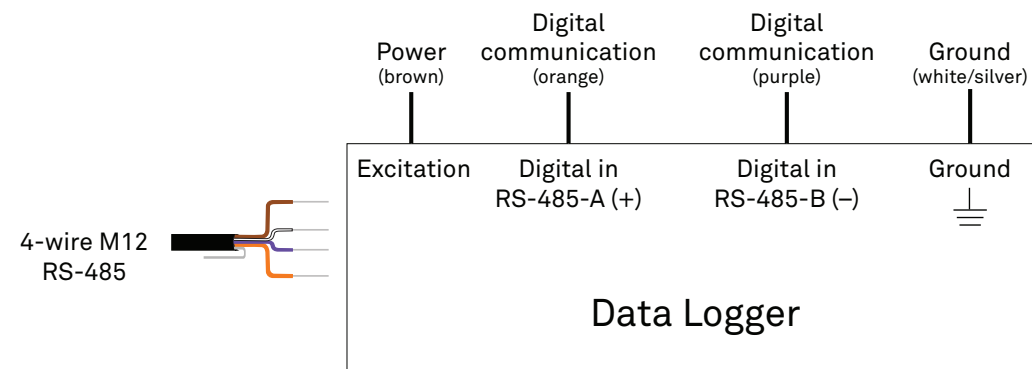

Figure 6 Four-wire M12 connector RS-485 wiring diagram

2.3 COMMUNICATION

The ATMOS 41 Gen 2 can communicate using any of the following protocols: SDI-12, or Modbus RS-485.

2.3.1 SDI-12

The SDI-12 protocol requires that all sensors have a unique address. ATMOS 41 Gen 2 sensor factory default is an SDI-12 address of 0. To add more than one SDI-12 sensor to a bus, the sensor address can be changed using a ZSC Bluetooth® sensor interface and the ZENTRA Utility Mobile app as described below:

NOTE: The sensor SDI-12 address must be returned to 0 to work with ZENTRA loggers.

1. Using a mobile device, open the ZENTRA Utility Mobile app.
2. Connect the sensor to the ZSC.
3. Under **Sensor Information**, select the SDI Address dropdown.
4. Scroll through the options and select the desired SDI-12 address.

NOTE: Address options include 0-9, A-Z, and a-z.

ATMOS 41 GEN 2

- **Barometric Pressure:** Each ATMOS 41 Gen 2 barometric pressure sensor is calibrated against the average of three secondary standard Measurement Specialties MS5611 pressure sensors. The MS5611 sensors are calibrated every 3 months against a GE Druck TERPS 8100-series pressure sensor. The GE pressure sensor is calibrated yearly at certified laboratory with NIST traceability.
- **Wind Speed:** The relationship between wind speed and phase is determined by geometry and the laws of physics. Since the geometry is tightly controlled in manufacture, no individual anemometer calibration is needed. The phase of each ATMOS 41 Gen 2 anemometer is initially set to zero in a zero wind-speed condition. Extensive wind-tunnel and field testing has shown this to result in accurate wind-speed measurements. A subsample of anemometers is checked monthly for accuracy as part of routine QA procedures.
- **Wind Direction:** The ATMOS 41 Gen 2 wind direction measurement depends on the geometry of the ultrasonic transducers and the north orientation indicator on the ATMOS 41 body. This geometry is held to within 0.025-mm specifications through CNC milling procedures. Orientation of the ATMOS 41 Gen 2 toward North will introduce more error in the wind direction measurement than sensor geometry.
- **Sensor Tilt:** The ATMOS 41 Gen 2 tilt sensor is zeroed against the primary bubble level on the bottom side of the upper anemometer housing.
- **Lightning Strike Counter:** Calibration on ATMOS 41 Gen 2 lightning strike detector is performed by the original manufacturer of the lightning detection chip prior to integration into the ATMOS 41. Verification that the lightning strike sensor meets specification is performed on each ATMOS 41 Gen 2 unit during QA procedures.
- **Lightning Distance:** Calibration on ATMOS 41 Gen 2 lightning distance detector is performed by the original manufacturer of the lightning detection chip prior to integration into the ATMOS 41 Gen 2. No further calibration is performed during sensor integration.

4.2 RECALIBRATION RECOMMENDATIONS

Table 3 lists the recommended sensor calibration frequencies.

Table 3 Sensor calibration frequencies

Sensor Function	Measurement Drift	Calibration Frequency
Solar radiation	<2% drift/year	Every 2 years ^a
Barometric pressure	0.1 kPa/year (typical)	Every 1–2 years ^b
Relative humidity	<0.25% RH/year	Every 2 years ^b
All other sensors		Not needed

4. SERVICE

This section contains calibration and recalibration information, calibration frequencies, cleaning and maintenance guidelines, troubleshooting guidelines, customer support contact information, and terms and conditions.

4.1 CALIBRATION

- **Solar Radiation:** ATMOS 41 pyranometers are calibrated through side-by-side comparison to the mean of four Apogee model SP-110 transfer standard pyranometers (shortwave radiation reference) under high-intensity discharge metal halide lamps. The transfer standard pyranometers are calibrated through side-by-side comparison to the mean of at least two ISO-classified reference pyranometers under sunlight (clear sky conditions) in Logan, Utah. Each of four ISO-classified reference pyranometers are recalibrated on an alternating yearly schedule (two instruments each year) at the National Renewable Energy Laboratory (NREL) in Golden, Colorado. NREL reference standards are calibrated to the World Radiometric Reference (WRR) in Davos, Switzerland.

METER recommends using the model from the Clear Sky Calculator, developed by Apogee Instruments, to determine uncertainty of the pyranometer on the ATMOS 41 Gen 2. The calculator is available on clearskycalculator.com or in the respective app store for a mobile device. Should the uncertainty be higher than 5% (or other preferred number) the unit should be replaced with a new funnel/pyranometer. Contact [Customer Support](#).

A custom pyranometer calibration factor can be calculated using the Clear Sky Calculator. Neither Apogee Instruments nor METER guarantee this method is as accurate as a new unit that has recently been calibrated, but, if done properly, it should result in better than 5% accuracy in the solar radiation measurements.

- **Precipitation:** ATMOS 41 rain gauges do not receive individual calibration. The critical parameter for accurate measurement is drop size (which is controlled by the geometry of the rain gauge nozzle), and the rain gauge nozzle is an injection molded piece with static geometry. The accuracy of each ATMOS 41 Gen 2 rain gauge is verified at a single rainfall rate during the manufacturing and quality assurance (QA) process. A subsample of rain gauges undergoes a more in-depth accuracy verification each month as part of routine QA procedures.
- **Air Temperature:** The air temperature sensor is specified to be accurate to 0.1 °C by the original manufacturer. All sensors are verified against a NIST-traceable standard thermometer at the time of manufacture.
- **RH/Vapor Pressure:** ATMOS 41 Gen 2 relative humidity/vapor pressure sensors receive a three-point calibration using a METER WP4C chilled-mirror dew point sensor as the calibration standard at 20%, 50%, and 80% RH. The WP4C is calibrated every 3 months against four salt standards of known RH (Robinson and Stokes 1970) to be accurate to within 0.2% RH.

Detailed information can also be found in the application note [Setting SDI-12 addresses on METER digital sensors using Campbell Scientific data loggers and LoggerNet](#) (<https://meter.ly/article-SDI-12-use-Campbell>).

When using the sensor as part of an SDI-12 bus, excite the sensors continuously to avoid issues with initial sensor startup interfering with the SDI-12 communications.

2.3.2 MODBUS RS-485

ATMOS 41 Gen 2 sensors communicate using the Modbus RTU protocol over RS-485. Modbus ASCII protocol is not supported.

The Modbus RTU protocol requires that all devices on the bus have a unique address. The ATMOS 41 Gen 2 sensor factory default is a Modbus RTU address of 1. Detailed information on changing the Modbus RTU address can be found in the ATMOS 41 Gen 2 [Integrator Guide](#) (<https://meter.ly/41support>). Details on Modbus data registers and other Modbus RS-485 connection information can also be found in the Integrator's Guide.

3. SYSTEM

This section describes the ATMOS 41 Gen 2 All-in-One Weather Station system.

3.1 SPECIFICATIONS

MEASUREMENT SPECIFICATIONS

Solar Radiation	
Range	0–1750 W/m ²
Resolution	1 W/m ²
Accuracy	±5% of measurement typical
Precipitation	
Range	0–1,500 mm/h
Resolution	0.017 mm
Accuracy	±5% of measurement from 0 to 1000 mm/hr
Vapor Pressure	
Range	0–47 kPa
Resolution	0.01 kPa
Accuracy	Varies with temperature and humidity, see specification chart.

HUMIDITY (%RH)	TEMPERATURE (°C)								
	0	10	20	30	40	50	60	70	80
100	± 0.03	± 0.05	± 0.09	± 0.16	± 0.27	± 0.44	± 0.69	± 1.33	± 2.38
90	± 0.03	± 0.05	± 0.09	± 0.15	± 0.26	± 0.42	± 0.66	± 1.26	± 2.24
80	± 0.03	± 0.04	± 0.07	± 0.12	± 0.21	± 0.34	± 0.63	± 1.20	± 2.10
70	± 0.02	± 0.04	± 0.07	± 0.12	± 0.20	± 0.32	± 0.50	± 1.13	± 1.96
60	± 0.02	± 0.03	± 0.06	± 0.11	± 0.18	± 0.30	± 0.47	± 1.06	± 1.82
50	± 0.02	± 0.03	± 0.06	± 0.10	± 0.17	± 0.28	± 0.45	± 0.99	± 1.68
40	± 0.02	± 0.03	± 0.05	± 0.09	± 0.16	± 0.26	± 0.42	± 0.76	± 1.54
30	± 0.01	± 0.03	± 0.05	± 0.09	± 0.15	± 0.24	± 0.39	± 0.69	± 1.40
20	± 0.01	± 0.02	± 0.04	± 0.08	± 0.14	± 0.23	± 0.36	± 0.62	± 1.26
10	± 0.01	± 0.02	± 0.04	± 0.07	± 0.12	± 0.21	± 0.33	± 0.55	± 1.13
0	± 0.01	± 0.02	± 0.04	± 0.06	± 0.11	± 0.19	± 0.30	± 0.48	± 0.99

Figure 7 Vapor pressure sensor accuracy

Relative Humidity	
Range	0–100% RH (0.00–1.00)

3.10.2 HEAVY RAIN AND STRONG WIND

During strong storm events, water can splash off of the convex base plate of the anemometer envelope and interrupt the signal passing between the ultrasonic transducers. The smooth convex surface of the base plate helps dissipate the energy of rainwater to minimize splashing and reduce the likelihood that the wind measurements are interrupted. Additionally, specially treated hydrophobic porous polyethylene membranes protect the ultrasonic transducers from direct splashing. Despite these features heavy rain and strong wind can still cause water to reach the membranes and also cause temporary water buildup on the base plate. The hydrophobic nature of the transducer protective membranes and the quick-draining ability of the base plate should limit wind measurement interruptions to heavy rain events and should bring wind measurement back online soon after extreme conditions abate.

3.10.3 ELECTROMAGNETIC INTERFERENCE

ATMOS 41 Gen 2 lightning and rainfall measurements can be adversely affected by high level Electromagnetic Interference (EMI), such as that produced by high voltage power transmission lines. Be sure to locate the ATMOS 41 Gen 2 far from sources of EMI.

3.8 BAROMETRIC PRESSURE SENSOR

The barometric pressure sensor is located behind the Teflon screen next to the relative humidity sensor. It measures the atmospheric pressure of the environment in which the ATMOS 41 Gen 2 is deployed. With a range from 50 to 110 kPa, it is suitable for measurement across a wide range of elevations, but keep in mind that the magnitude of sensor output will depend chiefly on the installation altitude with subtle changes caused by weather.

When powered on, the ATMOS 41 Gen 2 measures the barometric pressure once every 60 s and records the instantaneous values. When queried, the ATMOS 41 Gen 2 outputs the average of the instantaneous measurements since the last query.

3.9 TILT SENSOR

The ATMOS 41 Gen 2 is also equipped with a tilt sensor similar to those found in smartphones. The primary use of the tilt sensor data is to ensure the ATMOS 41 Gen 2 remains level at all times. Regularly check tilt data to ensure the ATMOS 41 Gen 2 is level; if it has tilted, return to the site and level again. Even a slightly off-level ATMOS 41 Gen 2 will cause errors in the solar radiation measurement, and a 2° tilt can cause large errors in the rainfall measurement.

Although this sensor may be used to level the instrument, it is much easier to use the small bubble level on the bottom of the anemometer plate.

When powered on, the ATMOS 41 Gen 2 measures the tilt in once every 60 s and records the instantaneous values. When queried, the ATMOS 41 Gen 2 outputs the average of the instantaneous measurements since the last query.

3.10 LIMITATIONS

The ATMOS 41 Gen 2 is engineered to be a robust device with minimal downtime. However, it does have limitations that will affect its measurements under some conditions.

3.10.1 SNOW AND ICE ACCUMULATION

The ATMOS 41 Gen2 is not heated, so it will not measure frozen precipitation until snow and ice that have accumulated in the funnel melt. In locations with heavy snowfall or long periods below freezing, it is almost certain that snow accumulation will fill the funnel and no longer accumulate, leading to inaccurate precipitation measurements even when the precipitation melts. Accumulation of snow, ice, or frost will also adversely affect the accuracy of the solar radiation measurement and can compromise the wind measurements if accumulation occurs in the anemometer acoustic pathway or on the convex base plate (Section 4.3). See the app note [Sensor and device maintenance: winter checklist](https://meter.ly/winter-checklist) (<https://meter.ly/winter-checklist>) for more information on ATMOS 41 Gen 2 performance in high-latitude winter.

Resolution	0.1% RH
Accuracy	Varies with temperature and humidity, see specification chart.

HUMIDITY (%RH)	100	±2.0%	±2.0%	±2.0%	±2.0%	±2.0%	±2.0%	±2.0%	±2.0%	
	90	±2.0%	±2.0%	±2.0%	±2.0%	±2.0%	±2.0%	±2.0%	±2.0%	
	80	±2.0%	±1.5%	±1.5%	±1.5%	±1.5%	±1.5%	±2.0%	±2.0%	
	70	±1.5%	±1.5%	±1.5%	±1.5%	±1.5%	±1.5%	±2.0%	±2.0%	
	60	±1.5%	±1.5%	±1.5%	±1.5%	±1.5%	±1.5%	±2.0%	±2.0%	
	50	±1.5%	±1.5%	±1.5%	±1.5%	±1.5%	±1.5%	±2.0%	±2.0%	
	40	±1.5%	±1.5%	±1.5%	±1.5%	±1.5%	±1.5%	±1.5%	±2.0%	
	30	±1.5%	±1.5%	±1.5%	±1.5%	±1.5%	±1.5%	±1.5%	±2.0%	
	20	±1.5%	±1.5%	±1.5%	±1.5%	±1.5%	±1.5%	±1.5%	±2.0%	
	10	±1.5%	±1.5%	±1.5%	±1.5%	±1.5%	±1.5%	±1.5%	±2.0%	
0	±1.5%	±1.5%	±1.5%	±1.5%	±1.5%	±1.5%	±1.5%	±2.0%		
		0	10	20	30	40	50	60	70	80

Figure 8 RH sensor accuracy

Hysteresis	±0.80% RH, typical
Long-Term Drift	±0.25% RH/year, typical

Air Temperature

Range	-50 to 60 °C
Resolution	0.1 °C
Sensor Accuracy	±0.2 °C
Measurement Uncertainty	±0.6 °C from -20 to 50 °C For more information see Section 3.6.1

Humidity Sensor Temperature

Range	-40 to 50 °C
Resolution	0.1 °C
Accuracy	±1.0 °C

SYSTEM

Barometric Pressure	
Range	1–120 kPa
Resolution	0.01 kPa
Accuracy	±0.05 kPa at 25 °C
Equilibration	< 10 ms
Long-Term Drift	< 0.1 kPa/year, typical
Horizontal Wind Speed	
Range	0–60 m/s
Resolution	0.01 m/s
Accuracy	The greater of 0.3 m/s or 3% of measurement
Wind Gust	
Range	0–60 m/s
Resolution	0.01 m/s
Accuracy	The greater of 0.3 m/s or 3% of measurement
Wind Direction	
Range	0°–359°
Resolution	1°
Accuracy	±5°
Tilt	
Range	–90° to 90°
Resolution	0.1°
Accuracy	±1°
Lightning Strike	
Range	0–65,535 strikes
Resolution	1 strike
Accuracy	Variable with distance, >25% detection at <10 km typical
Lightning Average Distance	
Range	0–40 km
Resolution	3 km
Accuracy	Variable

ATMOS 41 GEN 2

NOTE: A maximum value optimization for S_r was added because radiation values higher than that cause the corrected temperature to deviate from actual values more than when a maximum S_r was used.

Table 2 Optimized values for air temperature correction				
a_s	d (m)	k	c_p (J mol ⁻¹ K ⁻¹)	Max S_r (W/m ²)
0.295	0.00083	0.0984	29.3	352.3

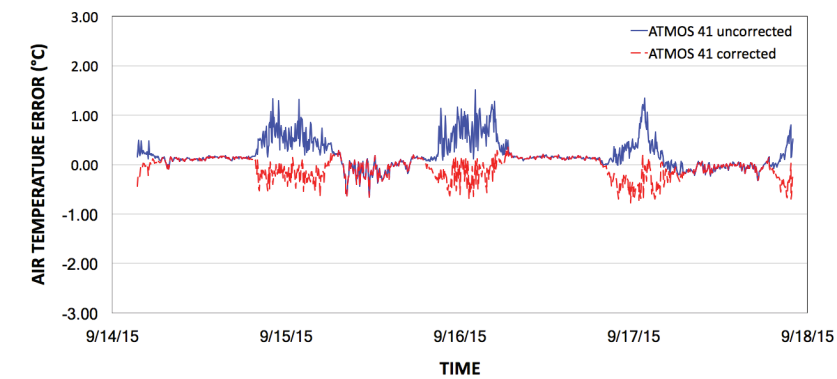

Figure 18 Corrected air temperature comparison with the aspirated radiation shield using 1-min measurement intervals

Figure 18 shows the results from the temperature correction compared to the aspirated temperature, which shows data sampled at 1 min and not averaged over time. The estimated accuracy of the air temperature measurement, based on two standard deviations (95% confidence interval), is 0.42 °C. To provide an idea of how comparable the data are, a concurrently tested temperature sensor in a radiation shield (typical measurement approach) showed an accuracy of 0.66 °C, also based on a two-standard deviation estimate. Thus, the temperature correction of the ATMOS 41 Gen 2 appears to give a better estimate of actual air temperature than the generally accepted radiation shield technique.

NOTE: Without correction, the accuracy of the temperature measurement is ±2 °C.

3.7 LIGHTNING SENSOR

The lightning sensor acts much like an AM radio. During a thunderstorm, the crack of the lightning disrupts the AM signal. The integrated circuit inside the sensor listens for this disturbance and registers the time of and distance (intensity of signal) to the strike. The sensor outputs the total number of strikes and average distance to these strikes in the measurement period. When powered on, the ATMOS 41 Gen 2 counts lightning events continuously and adds each detected event to an accumulated total. When queried, the ATMOS 41 Gen 2 outputs the total number of lightning events that have been detected since the last query.

SYSTEM

When powered on, the ATMOS 41 Gen 2 measures the air temperature once every 3 s and records the instantaneous values. When queried, the ATMOS 41 outputs the average of the instantaneous measurements since the last query.

NOTE: The ATMOS 41 body and especially the temperature sensor should not be painted or coated.

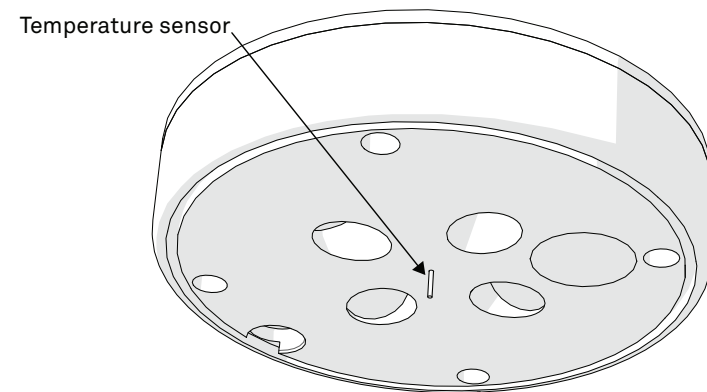

Figure 17 Temperature sensor

3.6.1 AIR TEMPERATURE THEORY

The ATMOS 41 uses an energy balance correction to adjust measured temperature to actual air temperature according to Equation 11.

$$T_{corr} = T_{uncorr} - \left(\frac{\alpha_s S_t}{c_p k \sqrt{u/d}} \right)$$

Equation 11

where:

α_s = the absorptivity of the surface to solar radiation

S_t = the total solar radiation measured

c_p = 29.3 J mol⁻¹ C⁻¹, k is a constant

u = the wind speed

d = the characteristic dimension

Although these values can be assumed, some (α_s and k) were optimized using a Levenberg Marquardt Least Squares analysis. Optimal air temperature was obtained using an Apogee TS-100 Aspirated Radiation Shield. Data were collected over several weeks and final values as shown in Table 2

ATMOS 41 GEN 2

COMMUNICATION SPECIFICATIONS

Output

SDI-12 communication

Modbus RS-485

Data Logger Compatibility

METER ZL6 and EM60 data loggers or any data acquisition systems capable of switched 3.6- to 15.0-VDC excitation and SDI-12 communication

Modbus RS-485 enabled ATMOS 41 Gen 2s are capable of SDI-12 communication and Modbus RS-485 with excitation 4 to 24 VDC.

PHYSICAL CHARACTERISTICS

Dimensions

Diameter 10 cm (3.9 in)

Height 28 cm (11.0 in), includes rain gauge filter

Operating Temperature Range

Minimum -50 °C

Typical NA

Maximum 60 °C

NOTE: Barometric pressure and relative humidity sensors operate accurately at a minimum of -40 °C.

Cable Length

5 m (stereo plug)

1.5 m (5-pin and 8-pin M12)

75 m (maximum custom cable length for additional cost)

NOTE: Contact [Customer Support](#) if a nonstandard cable length is needed.

Connector Types

Stereo plug connector or 3 stripped and tinned wires

5-pin M12 connector or 5 stripped and tinned wires

8-pin M12 connector or 5 stripped and tinned wires

Plug Connector Diameter

Stereo Plug with 4.2 ±0.2 mm (0.16 ±0.01 in), minimum jacket of 0.8mm (0.031 in)

M12 Plug with 5.5 ±0.2 mm (0.22 ±0.01 in), minimum jacket of 1.0 mm (0.039 in)

SYSTEM

Conductor Gauge	
	22-AWG / 24-AWG drain wire
Cable Diameter	
	0.165 ±0.004 in (4.20 ±0.10 mm), with minimum jacket of 0.030 in (0.76 mm)
ELECTRICAL AND TIMING CHARACTERISTICS	
Supply Voltage (VCC to GND)	
Minimum	3.6 VDC continuous
Typical	NA
Maximum	15.0 VDC continuous
NOTE: ATMOS 41 Gen 2 must be continuously powered to work properly.	
NOTE: For the ATMOS 41 Gen 2 to meet digital logic levels specified by SDI-12, it must be excited at 3.9 VDC or greater.	
Digital Input Voltage (logic high)	
Minimum	2.8 V
Typical	3.0 V
Maximum	5.5 V
Digital Input Voltage (logic low)	
Minimum	-0.3 V
Typical	0.0 V
Maximum	0.8 V
Digital Output Voltage (logic high)	
Minimum	NA
Typical	3.6 V
Maximum	NA
NOTE: For the ATMOS 41 Gen 2 to meet digital logic levels specified by SDI-12, it must be excited at 3.9 VDC or greater.	
Power Line Slew Rate	
Minimum	1.0 V/ms
Typical	NA
Maximum	NA

ATMOS 41 GEN 2

3.5.2 ELECTRICAL CONDUCTIVITY (EC)

The ATMOS 41 Gen 2 has a small basin that collects a sample of the precipitation stream as the tipping spoon empties. Two small sensing electrodes measure the electrical conductivity (EC) of the water in this basin every time the rainfall tipping spoon tips and records the instantaneous values. At the end of the measurement interval, the ATMOS 41 Gen 2 outputs the average of the instantaneous values measured during that measurement interval. Measurement intervals with no spoon tips are represented with a 0 value reported for EC.

There are several factors that affect the EC of the water in the measurement basin. The most important of these and the quantity that is most desirable to measure is the EC of the precipitation or irrigation water itself. However, the presence of atmospheric depositions and especially biological substances (e.g., bird droppings) in the funnel will heavily influence the EC of the water in the basin until those compounds are completely flushed from the system. In the case of bird droppings, this may not happen completely even after several precipitation events. Please see [Section 5.4](#) for instructions on cleaning the funnel.

Residual water and concentrated solutes in the measurement basin will also influence the EC measurement until the residual water and solutes are completely flushed from the basin. Additionally, microbial activity in the measurement basin can lead to biofouling of the electrodes, which can compromise their ability to measure EC. Please see [Section 5.4](#) for instructions on cleaning the EC electrodes.

If an accurate measure of precipitation and irrigation water EC is desired, it is critical to keep both the funnel and the EC measurement basin clean between precipitation and irrigation events. Ignore data from early in the event until the whole system is flushed and the measurement basin is filled with uncompromised precipitation and irrigation water.

Even if the funnel and measurement basin are not routinely cleaned, the EC of the solution passing through the measurement basin during precipitation events can be used as an indicator that the funnel has been polluted by bird droppings and needs to be cleaned for proper rainfall measurement.

3.6 TEMPERATURE SENSOR

The ATMOS 41 Gen 2 temperature measurement ([Figure 17](#)) is made in the center of the anemometer area where a small stainless steel needle containing a tiny temperature sensor (thermistor) extends from the middle of the four ultrasonic transducers in the center of the anemometer. Unlike most air temperature measurements, the weather station sensor is not covered with louvered plates to protect from solar heating. Instead, it sits in open air, susceptible to solar heating of the instrument body. However, the ATMOS 41 Gen 2 calculates the air temperature accurately because solar radiation and the wind speed are known. These are the two main parameters that determine the error between measured air temperature and the actual air temperature. Therefore, it is possible to solve the energy balance to get what the actual temperature should be based on the solar load of the body and the convective cooling of that temperature sensor.

SYSTEM

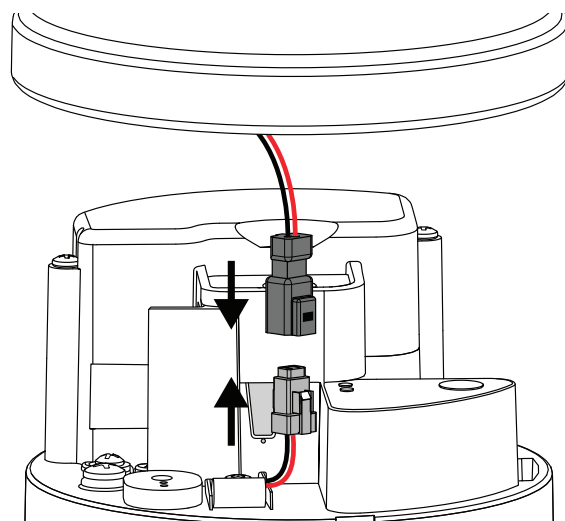

Figure 15 Connect pyranometer cable

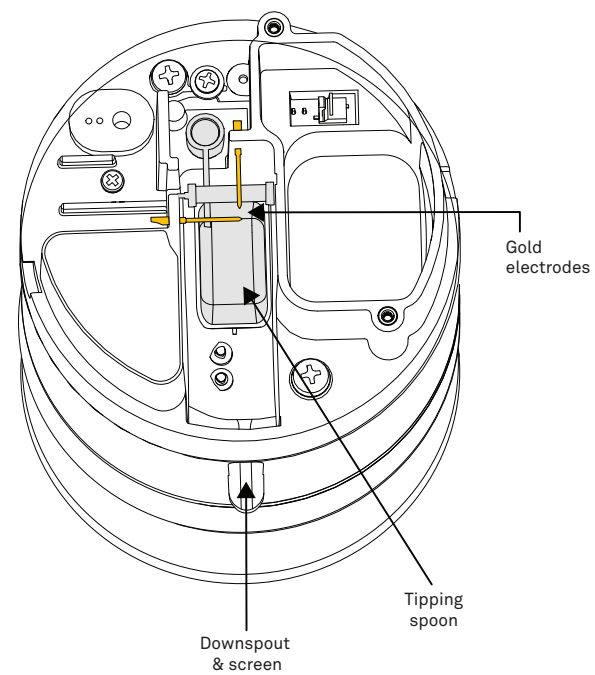

Figure 16 Downspout and screen

ATMOS 41 GEN 2

Current Drain (during measurement)

Minimum	0.2 mA
Typical	8.0 mA
Maximum	33.0 mA

Current Drain (while asleep)

Minimum	0.2 mA
Typical	0.3 mA
Maximum	0.4 mA

Power Up Time (SDI ready)—aRx! Commands

Minimum	NA
Typical	3 s
Maximum	NA

Power Up Time (SDI ready)—Other Commands

Minimum	NA
Typical	800 ms
Maximum	NA

Power Up Time (SDI-12, DDI Serial disabled)

Minimum	NA
Typical	240 ms
Maximum	NA

Measurement Duration

Minimum	NA
Typical	240 ms
Maximum	3,000 ms

COMPLIANCE

EM ISO/IEC 17050:2010 (CE Mark)

3.2 SOLAR RADIATION (PYRANOMETER)

Solar radiation is measured by a pyranometer that is integrated into the lip of the rain gauge funnel at the top of the ATMOS 41 Gen 2. Designed, manufactured, and calibrated by experts at Apogee Instruments, the miniature pyranometer uses a silicon-cell sensor to measure the total incoming (direct and diffuse) solar radiation. A carefully developed cosine-correcting head ensures accurate readings regardless of sun angle, while the painstakingly researched optical filter material balances cost and performance to ensure the silicon-cell provides good accuracy regardless of temperature or sensor age. Silicon-cell sensors have excellent response time to changing radiation conditions and acceptable sensitivity across the solar spectrum (Figure 9), which make them perfect for use on the ATMOS 41 Gen 2.

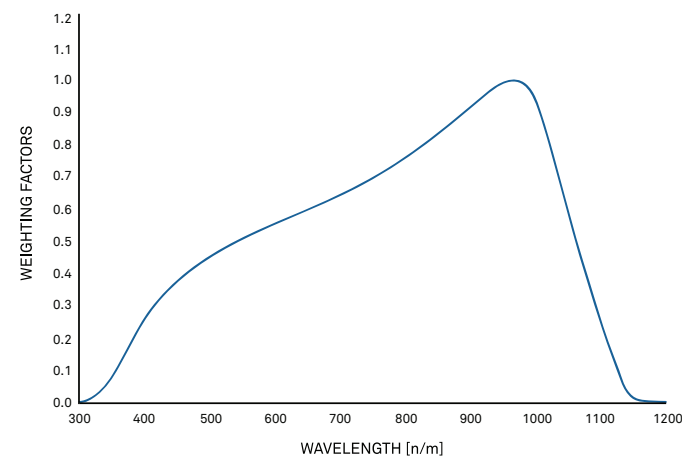

Figure 9 Spectral response estimate of Apogee silicon-cell pyranometers

Spectral response was estimated by multiplying the spectral response of the photodiode, diffuser, and adhesive. Spectral response measurements of diffuser and adhesive were made with a spectrometer, and spectral response data for the photodiode were obtained from the manufacturer.

Leveling the ATMOS 41 Gen 2 is particularly important for accurate solar radiation measurements. Out of level, the pyranometer will overestimate some portions of the day while under-estimating others. Ensure accurate solar radiation measurements by carefully leveling the ATMOS 41 Gen 2 at installation. Bird droppings and other soiling of the domed sensor surface will cause serious errors in pyranometer measurements. Check the sensor regularly to make sure it is clean and check data often to identify possible problems. Isopropyl (rubbing) alcohol and a Q-tip works well for cleaning the sensor area. Microfiber bags work well, too. Do NOT use an abrasive cloth on the sensor surface, as it will scratch.

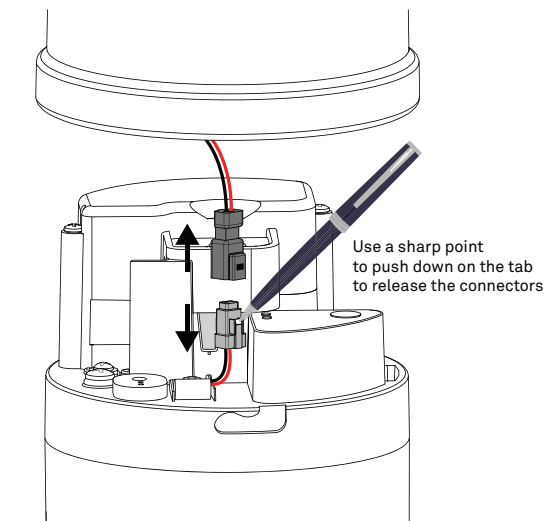

Figure 14 Disconnect pyranometer connector

3.5.1.2 REATTACH PYRANOMETER AND RAIN FUNNEL

The following instructions explain how to replace the rain funnel. Before replacing the funnel, do the following:

1. Reattach the pyranometer connector by mating the two halves of the white connector and seating them firmly together until the tabs lock (Figure 15).

NOTE: The connector is keyed and will only connect if oriented correctly.

2. Check to be sure the downspout screen is in place on the water exit downspout (Figure 16) before replacing the rain funnel.

NOTE: This keeps insects out of the interior of the instrument.

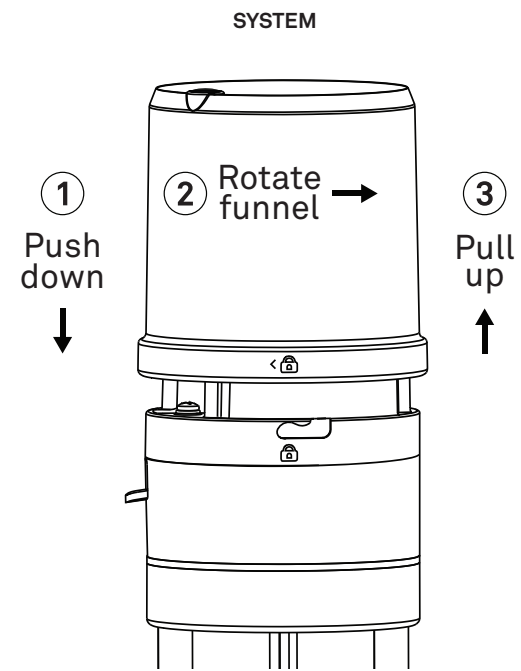

Figure 13 Removing ATMOS 41 Gen 2 rain funnel

3.5.1.1 DISCONNECT PYRANOMETER AND RAIN FUNNEL

Before removing the rain funnel completely, carefully disconnect the pyranometer from the ATMOS 41 Gen 2 base by disconnecting the pyranometer connector as described below and shown in [Figure 14](#)

1. Press in the tabs on both sides of the connector locking mechanism with a sharp-pointed object (e.g., a ballpoint pen).
2. Once the tabs are released, pull the connectors apart.
3. Place the rain funnel aside.

IMPORTANT

Unplug the pyranometer connector inside the rain funnel before fully removing the funnel ([Figure 14](#)).

ATMOS 41 GEN 2

The pyranometer is factory calibrated and the sensor-specific calibration value can be found on the interior of the rain funnel. This factor has already been added into the ATMOS 41 so there is no need to do anything with it. In the event that this value is needed, it can be found by taking the funnel off the base and checking underneath. Follow the steps in [Section 3.5](#) to remove the funnel.

When powered on, the ATMOS 41 Gen 2 measures the solar radiation once every 3 s and records the instantaneous values. When queried, the ATMOS 41 Gen 2 outputs the average of the instantaneous measurements since the last query.

3.3 WIND SPEED AND DIRECTION (ANEMOMETER)

The space underneath the rain gauge is where the ATMOS 41 Gen 2 measures wind speed. Ultrasonic signals emitted from transducers orthogonal to each other bounce off the convex base plate ([Figure 10](#)) and back up to the other sensors. The speed of sound is affected by the wind, and the wind speed is calculated by measuring differences in the time it takes for sound to travel back and forth between sensors ([Section 3.3.1](#)).

When powered on, the ATMOS 41 Gen 2 measures the wind speed and direction once every 3 s and records the instantaneous wind vector components. When queried, the ATMOS 41 Gen 2 outputs the average of the instantaneous measurements since the last query for wind speed and direction and the maximum instantaneous wind speed value for wind gust.

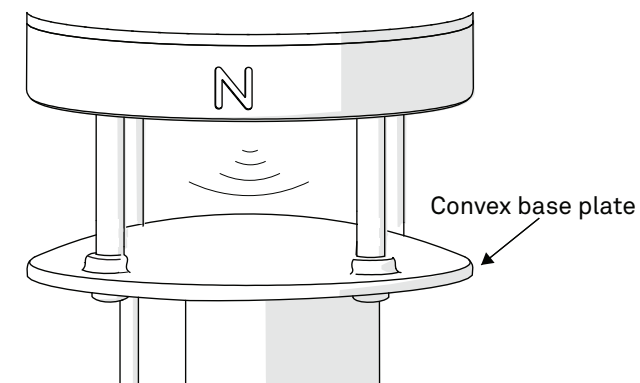

Figure 10 Anemometer

The ATMOS 41 Gen 2 measures wind speed every 3 s and keeps a running average of the last 10 measurements. If an instantaneous measurement is more than eight times the running average, the instantaneous measurement is rejected. It is not reported as the maximum gust or included in the data that are averaged over the output interval.

SYSTEM

For normal ATMOS 41 Gen 2 use cases, this is an effective method for eliminating inaccuracy resulting from spurious spikes in wind speed (e.g., bumblebee checking out the ultrasonic path). In special use cases where data are output frequently and large step changes in wind speed are present (e.g., turning on a wind tunnel), this spike rejection algorithm may result in an error code being output.

3.3.1 WIND SPEED AND DIRECTION THEORY

The theory behind the anemometer comes from Campbell and Unsworth (1979). The speed c (m/s) of sound in still air depends on air temperature T (K), vapor pressure e (kPa), and atmospheric pressure, p (kPa), as shown in [Equation 1](#).

$$c = 20.067 \sqrt{T \left(1 + \frac{0.32e}{p} \right)}$$

Equation 1

For a given sound path length, d (m), the number of wavelengths, n , in still air is determined with [Equation 2](#).

$$n = \frac{vd}{c}$$

Equation 2

Here v is the frequency of the sound (Hz). When the air is moving, the speed of sound is the sum of the wind speed and the speed of sound in still air. The anemometer transmits a sound pulse in a forward direction, then a similar pulse in the reverse direction. The difference in n between the two points is computed. If the vector magnitude of the wind in the direction of the sound is u (m/s), then

$$n - \Delta n_+ = \frac{vd}{c+u}$$

Equation 3

$$n + \Delta n_- = \frac{vd}{c-u}$$

Equation 4

for sound traveling with and against the wind. Subtracting the result of [Equation 3](#) from the results of [Equation 4](#) creates [Equation 5](#).

ATMOS 41 GEN 2

- **The drop counter ensures that any water that comes through the funnel is counted in the total.** The resolution of the drop counter is 0.017 mm, which is an order of magnitude better than conventional tipping spoon gauges. Small amounts of rainfall that are insufficient to cause the spoon to tip can evaporate over time and therefore, never be counted in the rainfall total.

The tipping spoon adds robustness to the ATMOS 41 Gen 2 rainfall measurement in the following ways:

- Extends the measurement range to capture extreme rainfall events of up to 2000 mm/hr (the drop-counting method becomes unreliable at extremely high rainfall rates [>400 mm/hr]).
- Extends the off-level tolerance for rainfall measurement. If the ATMOS 41 Gen 2 is off-level by significantly more than 2 degrees, drops can miss the gold pins and will not be counted.
- The tipping spoon is not susceptible to electromagnetic interference (EMI). In some extreme cases, close proximity lightning or other strong sources of EMI can manifest as artificial drops to the drop counters.

IMPORTANT

The ATMOS 41 Gen 2 must be within approximately $\pm 2^\circ$ of dead level to measure rainfall with the best resolution. If not within this range, drops from the flared hole can miss the gold electrodes entirely.

3.5.1 REMOVE RAIN FUNNEL

The rain funnel may occasionally need to be removed in the following instances:

- Starting (or restarting) the Bluetooth connection ([Section 2.2.1](#)),
- Cleaning ([Section 5.4](#)),
- Replacing the rain funnel for pyranometer recalibration.

The rain funnel locks in place using two pegs on the side of the rain funnel. To remove the rain funnel do the following:

1. Discharge static electricity from the ATMOS 41 Gen 2 body by touching any conductive material not isolated from the ground (e.g., metal pole).
NOTE: An electrostatic discharge (ESD) can damage ATMOS 41 Gen 2 electronics.
2. Press the rain funnel down to compress the internal spring.
3. Twist counter-clockwise to unlock from the ATMOS 41Gen 2 base until the lock/unlock graphic located on the side of the rain gauge funnel is lined up with the notch on the interface plate ([Figure 15](#)).
4. Carefully lift off the rain funnel.

⚠ CAUTION

Remove the rain funnel carefully to avoid damaging the pyranometer connector wire.

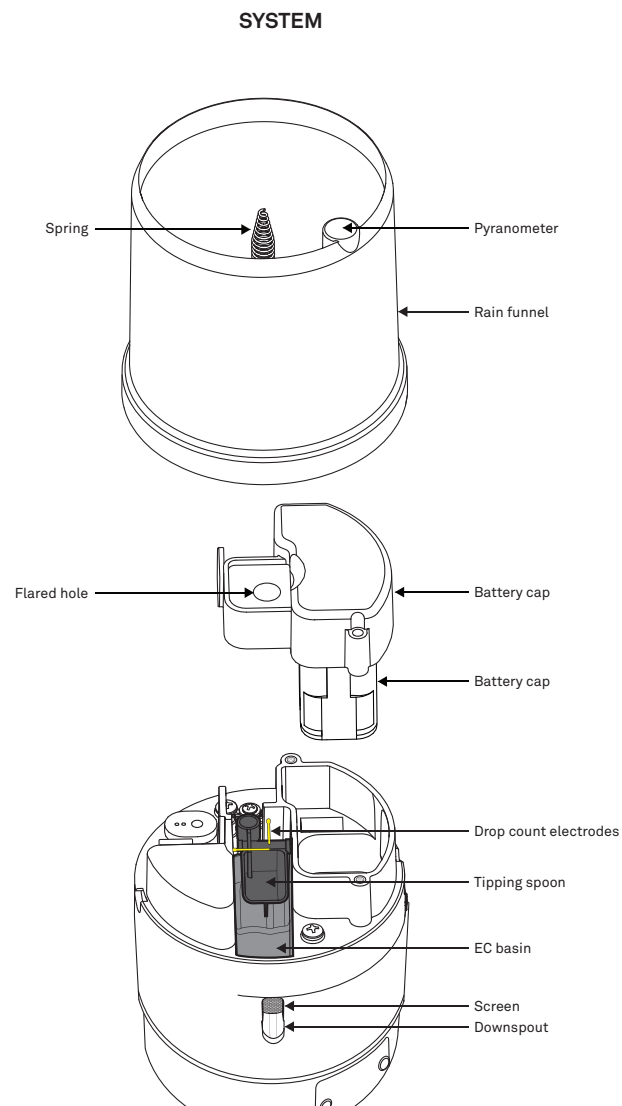

Figure 12 Rain funnel and rain gauge

The drop counter adds robustness and resolution to the precipitation measurement in the following ways:

- **The drop counter does not have moving parts and is not subject to mechanical wear and particulate contamination issues that can cause inaccuracy or complete failure.** The tipping spoon mechanisms do have moving parts with friction surfaces and are subject to mechanical wear and particulate contamination issues.

ATMOS 41 GEN 2

$$\Delta n = \Delta n_- + \Delta n_+ = \frac{2\nu du}{c^2 - u^2}$$

Equation 5

Even at the maximum wind speeds for the anemometer, u^2 is only about 1% of c^2 , so the equation can be simplified as shown in Equation 6.

$$u \cong \frac{c^2}{2\nu d} \Delta n$$

Equation 6

This is the basic equation for the anemometer. Delta (Δ) n is proportional to the phase difference between the forward and reverse sound pulses. The sound comes from a 40 kHz ultrasonic transducer in the head of the anemometer. A sound pulse is transmitted orthogonally across the anemometer measurement pathway, bouncing off the convex baseplate in the center. The sound pulse is then received by the other transducers in the anemometer. Once the sound pulse is received, the receiver becomes the transmitter and the process is repeated. A total of four transducers send and receive sound pulses in succession to give the horizontal component of the wind. The sound travels a total distance of about 65 mm from transmitter to receiver, but d in the equations is just the horizontal distance, which is 27 mm.

If u is the magnitude of the wind vector in the east-west direction (east +) and v is the magnitude in the north-south direction (north +), then wind speed is computed with Equation 7.

$$S = \sqrt{\bar{u}^2 + \bar{v}^2}$$

Equation 7

Where the overbar indicates an average of the values sampled every 10 s, wind direction is computed with Equation 10.

$$\theta = \tan^{-1}(\bar{v} / \bar{u})$$

Equation 8

The wind measurement through more frequent SDI-12 commands requires 42 ms to complete. An additional 60 ms are required for the computations to determine phase differences. The anemometer samples every 3 s (or more often if requested). The gust speed reported is the highest instantaneous wind speed measured during the selected averaging interval (must be >20 s or gusts will equal speed).

SYSTEM

NOTE: Cup anemometers average over a much longer interval than 42 ms, so the gusts measured with an ultrasonic anemometer will have a larger peak-to-mean ratio than one would see with a cup anemometer.

3.4 VAPOR PRESSURE/RELATIVE HUMIDITY SENSOR

The vapor pressure sensor (Figure 11) on the ATMOS 41 Gen 2 is located behind the access door in the same housing as the ultrasonic transducers. The Teflon screen protects the sensor from liquid water and dust while allowing water vapor to freely pass to the sensor and equilibrate with air vapor pressure. The sensor measures relative humidity and temperature in addition to computing vapor pressure.

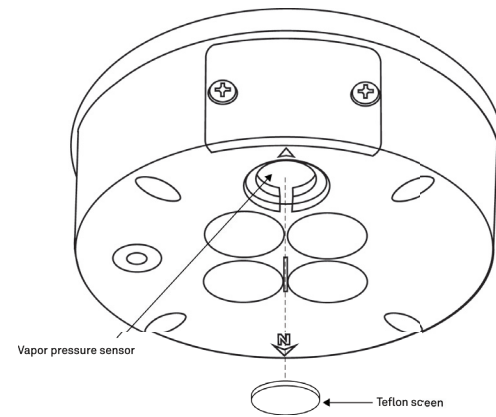

Figure 11 Vapor pressure sensor

If the relative humidity of the air is desired, it can be computed using Equation 9.

$$RH_{r,air} = \frac{e_a}{e_s(T_{air})}$$

Equation 9

where e_a is the vapor pressure of the air, from the ATMOS 41 Gen 2, and $e_s(T_{air})$ is saturation vapor pressure at the air temperature given by the ATMOS 41 Gen 2.

The saturation vapor pressure is calculated using the Magnus-Tetens equation (Equation 10) with the following coefficients described by Buck (1981).

$$e_s T_{air} = a \exp\left(\frac{b T_{air}}{c + T_{air}}\right)$$

Equation 10

ATMOS 41 GEN 2

Water	$a = 0.611 \text{ kPa}$	$b = 17.502$	$c = 240.97 \text{ }^\circ\text{C}$	T_{air} = Temperature in $^\circ\text{C}$
Ice	$a = 0.611 \text{ kPa}$	$b = 21.87$	$c = 265.5 \text{ }^\circ\text{C}$	T_{air} = Temperature in $^\circ\text{C}$

Unlike relative humidity, vapor pressure does not depend on temperature, and is generally conservative over time and space. The vapor pressure of the atmosphere near the relative humidity sensor is the same as the vapor pressure at the relative humidity sensor, even if the relative humidity sensor is not at the same temperature as the atmosphere. Additionally, it is the vapor pressure of the atmosphere (not RH) that controls the rate of vapor phase water transport (e.g., evaporation, transpiration, and distribution of water vapor). Therefore, vapor pressure is a much more useful measure of atmospheric moisture than relative humidity.

The METER ZENTRA system calculates and outputs vapor pressure deficit (VPD) in the standard data stream. VPD is simply $e_s(T_{air}) - e_a$ and gives a good indication of evaporative demand.

When powered on, the ATMOS 41 Gen 2 measures the vapor pressure once every 3 s and records the instantaneous values. When queried, the ATMOS 41 Gen 2 outputs the average of the instantaneous measurements since the last query.

3.5 PRECIPITATION

The ATMOS 41 Gen 2 contains a 9.31-cm diameter rain funnel and two methods to measure rainfall. During a rain event, precipitation first goes into the rain funnel where the spring (Figure 12) acts as a filter to keep out large particles but still allows enough flow so water does not back up. After flowing past the spring and into the rain gauge, precipitation flows through the flared hole (Figure 12) to form drops of a consistent and known size that then pass by the drop counter for the primary rainfall measurement.

The drop counter consists of two gold electrodes (Figure 12) that measure each drop formed by the flared hole. Because the flared hole forms a drop of a known size, the ATMOS 41 Gen 2 can calculate water volume from the number of drops counted.

After passing the drop counter, the drops land in the tipping spoon reservoir for a secondary rainfall measurement. The tipping spoon is precisely calibrated to tip with a highly-repeatable water volume. Each time the spoon tips, a magnet passes a Hall-effect sensor and the tip event is recorded.