



METER

ECH₂O 5TM INTEGRATOR GUIDE

SENSOR DESCRIPTION

The ECH₂O 5TM sensor is a low-cost, accurate tool for monitoring volumetric water content and temperature in soils. All measurements are made independently. As with all ECH₂O sensors, the 5TM determines volumetric water content (VWC) by measuring the dielectric constant of the media using capacitance/frequency domain technology. The sensor uses a 70-MHz frequency, which minimizes textural and salinity effects, making the 5TM accurate in most soils. The 5TM measures temperature using an onboard thermistor.

For a more detailed description of how this sensor makes measurements, refer to the [5TM User Manual](#).

APPLICATIONS

- Volumetric water content (VWC) measurement
- Soil-water storage measurement
- Irrigation management
- Soil temperature measurement
- Modeling processes that are affected by temperature

ADVANTAGES

- Robust thermistor for accurate temperature measurements
- Robust epoxy encapsulation resists corrosive environments
- Three-wire sensor interface: power, ground, and data
- Digital sensor communicates multiple measurements over a serial interface
- Low-input voltage requirements
- Low-power design supports battery-operated data loggers
- Supports SDI-12 or DDI serial communications protocols
- Modern design optimized for low-cost sensing

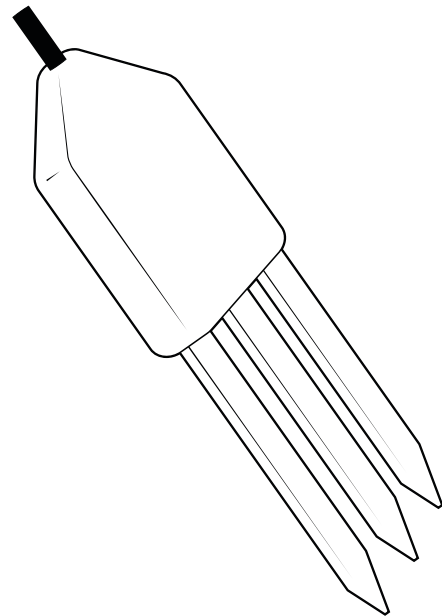

Figure 1 5TM sensor

PURPOSE OF THIS GUIDE

METER provides the information in this integrator guide to help 5TM customers establish communication between these sensors and their data acquisition equipment or field data loggers. Customers using data loggers that support SDI-12 sensor communications should consult the data logger user manual. METER sensors are fully integrated into the METER system of plug-and-play sensors, cellular-enabled data loggers, and data analysis software. For more information about METER-integrated systems, please contact [Customer Support](#).

COMPATIBLE FIRMWARE VERSIONS

This guide is compatible with firmware versions 3.29 or newer.

SPECIFICATIONS

MEASUREMENT SPECIFICATIONS

Volumetric Water Content (VWC)		Accuracy	
Range		Generic calibration	±0.03 m ³ /m ³ typical
Mineral soil calibration	0.0–1.0 m ³ /m ³	Medium-specific calibration	±0.02 m ³ /m ³
Soilless media calibration	0.0–1.0 m ³ /m ³	Apparent dielectric permittivity (ϵ_a)	1–40 (soil range), ±1 ϵ_a (unitless) 40–80, 15% measurement
Apparent dielectric permittivity (ϵ_a)	1 (air) to 80 (water)		
Resolution	0.0008 m ³ /m ³ from 0%–50% VWC		
Temperature			
Range		Range	–40 to +60 °C
		Resolution	1 °C
		Accuracy	±1 °C

COMMUNICATION SPECIFICATIONS

Output	Data Logger Compatibility
DDI serial or SDI-12 communication protocol	Any data acquisition system capable of 3.6- to 15-VDC power and serial or SDI-12 communication

PHYSICAL SPECIFICATIONS

Dimensions	Cable Length
Length	5 m (standard) 75 m (maximum custom cable length)
Width	NOTE: Contact Customer Support if a nonstandard cable length is needed.
Height	
Prong Length	Connector Types
5.0 cm (1.9 in)	3.5-mm stereo plug connector or stripped and tinned wires
Operating Temperature Range	
Minimum	–40 °C
Typical	NA
Maximum	+60 °C
NOTE: Sensors may be used at higher temperatures under certain conditions; contact Customer Support for assistance.	

ELECTRICAL AND TIMING CHARACTERISTICS

Supply Voltage (VCC to GND)	Digital Input Voltage (logic low)
Minimum	–0.3 V
Typical	0.0 V
Maximum	0.8 V
Digital Input Voltage (logic high)	Power Line Slew Rate
Minimum	1.0 V/ms
Typical	NA
Maximum	NA

Current Drain (during measurement)		Power Up Time (SDI-12)	
Minimum	0.5 mA	Minimum	100 ms
Typical	3.0 mA	Typical	150 ms
Maximum	10.0 mA	Maximum	200 ms
Current Drain (while asleep)		Measurement Duration	
Minimum	NA	Minimum	NA
Typical	0.03 mA	Typical	150 ms
Maximum	NA	Maximum	200 ms
Power Up Time (DDI serial)			
Minimum	NA		
Typical	NA		
Maximum	100 ms		

COMPLIANCE

Manufactured under ISO 9001:2015

EM ISO/IEC 17050:2010 (CE Mark)

EQUIVALENT CIRCUIT AND CONNECTION TYPES

Refer to [Figure 2](#) and [Figure 3](#) to connect the 5TM to a data logger. [Figure 2](#) provides a low-impedance variant of the recommended SDI-12 specification.

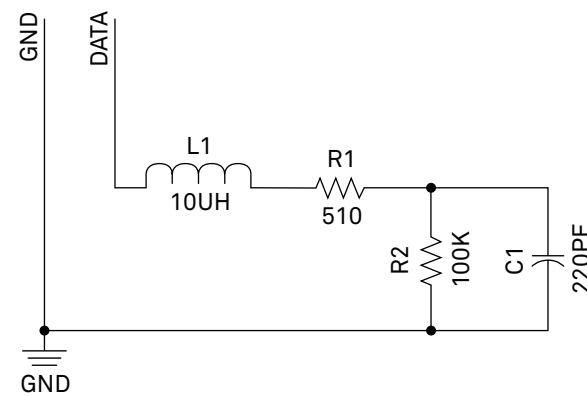

NOTE: This is a low-impedance variant of the recommended SDI-12 specification. This allows as many as 62 sensors to be maintained on a bus.

Figure 2 Equivalent circuit diagram

PIGTAIL CABLE

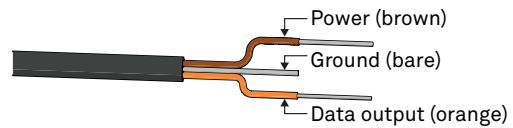

NOTE: Some early 5TM units may have the older Decagon wiring scheme where the power supply is white, the digital out is red, and the bare wire is ground.

STEREO CABLE



Figure 3 Connection types

⚠ PRECAUTIONS

METER sensors are built to the highest standards, but misuse, improper protection, or improper installation may damage the sensor and possibly void the warranty. Before integrating sensors into a sensor network, follow the recommended installation instructions and implement safeguards to protect the sensor from damaging interference.

SURGE CONDITIONS

Sensors have built-in circuitry that protects them against common surge conditions. Installations in lightning-prone areas, however, require special precautions, especially when sensors are connected to a well-grounded third-party logger.

Read the application note [Lightning surge and grounding practices](#) on the METER website for more information.

POWER AND GROUNDING

Ensure there is sufficient power to simultaneously support the maximum sensor current drain for all the sensors on the bus. The sensor protection circuitry may be insufficient if the data logger is improperly powered or grounded. Refer to the data logger installation instructions. Improper grounding may affect the sensor output as well as sensor performance.

Read the application note [Lightning surge and grounding practices](#) on the METER website for more information.

CABLES

Improperly protected cables can lead to severed cables or disconnected sensors. Cabling issues can be caused by many factors, including rodent damage, driving over sensor cables, tripping over the cable, not leaving enough cable slack during installation, or poor sensor wiring connections. To relieve strain on the connections and prevent loose cabling from being inadvertently snagged, gather and secure the cable travelling between the 5TM and the data acquisition device to the mounting mast in one or more places. Install cables in conduit or plastic cladding when near the ground to avoid rodent damage. Tie excess cable to the data logger mast to ensure cable weight does not cause sensor to unplug.

SENSOR COMMUNICATIONS

METER digital sensors feature a serial interface with shared receive and transmit signals for communicating sensor measurements on the data wire ([Figure 3](#)). The sensor supports two different protocols: SDI-12 and DDI serial. Each protocol has implementation advantages and challenges. Please contact [Customer Support](#) if the protocol choice for the desired application is not obvious.

SDI-12 INTRODUCTION

SDI-12 is a standards-based protocol for interfacing sensors to data loggers and data acquisition equipment. Multiple sensors with unique addresses can share a common 3-wire bus (power, ground, and data). Two-way communication between the sensor and logger is possible by sharing the data line for transmit and receive as defined by the standard. Sensor measurements are triggered by protocol command. The SDI-12 protocol requires a unique alphanumeric sensor address for each sensor on the bus so that a data logger can send commands to and receive readings from specific sensors.

Download the [SDI-12 Specification v1.3](#) to learn more about the latest SDI-12 protocol.

DDI SERIAL INTRODUCTION

The DDI serial protocol is the method used by the METER data loggers for collecting data from the sensor. This protocol uses the data line configured to transmit data from the sensor to the receiver only (simplex). Typically, the receive side is a microprocessor UART or a general-purpose I/O pin using a bitbang method to receive data. Sensor measurements are triggered by applying power to the sensor.

INTERFACING THE SENSOR TO A COMPUTER

The serial signals and protocols supported by the sensor require some type of interface hardware to be compatible with the serial port found on most computers (or USB-to-serial adapters). There are several SDI-12 interface adapters available in the marketplace; however, METER has not tested any of these interfaces and cannot make a recommendation as to which adapters work with METER sensors. METER data loggers and the ProCheck hand-held device can operate as a computer-to-sensor interface for making on-demand sensor measurements. For more information, please contact [Customer Support](#).

METER SDI-12 IMPLEMENTATION

METER sensors use a low-impedance variant of the SDI-12 standard sensor circuit ([Figure 2](#)). During the power-up time, the sensors output some sensor diagnostic information and should not be communicated with until the power-up time has passed. After the power-up time, the sensors are compatible with all commands listed in the [SDI-12 Specification v1.3](#).

Out of the factory, all METER sensors start with SDI-12 address 0 and print out the DDI serial startup string during the power-up time. This can be interpreted by non-METER SDI-12 sensors as a pseudo-break condition followed by a random series of bits.

The 5TM will omit the DDI serial startup string (sensor identification) when the SDI-12 address is nonzero. Changing the address to a nonzero address is recommended for this reason.

SENSOR BUS CONSIDERATIONS

SDI-12 sensor buses require regular checking, sensor upkeep, and sensor troubleshooting. If one sensor goes down, that may take down the whole bus even if the remaining sensors are functioning normally. Power cycling the SDI-12 bus when a sensor is failing is acceptable, but METER does not recommend scheduling power cycling events on an SDI-12 bus more than once or twice per day. Many factors influence the effectiveness of the bus configuration. Visit metergroup.com for articles and virtual seminars containing more information.

SDI-12 CONFIGURATION

Table 1 lists the SDI-12 communication configuration.

Table 1 SDI-12 communication configuration

Baud Rate	1200
Start Bits	1
Data Bits	7 (LSB first)
Parity Bits	1 (even)
Stop Bits	1
Logic	Inverted (active low)

SDI-12 TIMING

All SDI-12 commands and responses must adhere to the format in Figure 4 on the data line. Both the command and response are preceded by an address and terminated by a carriage return and line feed combination (<CR><LF>) and follow the timing shown in Figure 5.

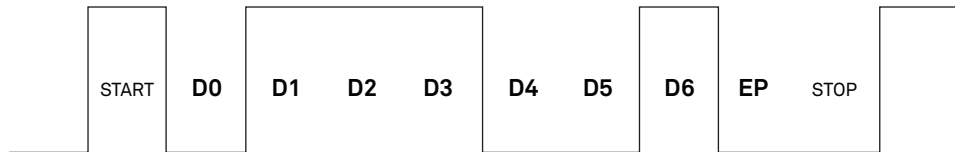

Figure 4 Example SDI-12 transmission of the character 1 (0x31)

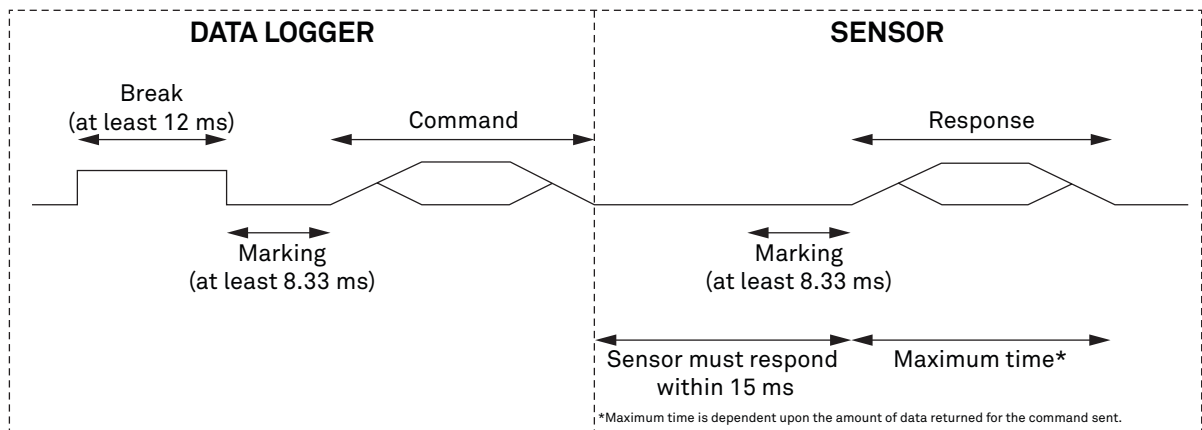

Figure 5 Example data logger and sensor communication

COMMON SDI-12 COMMANDS

This section includes tables of common SDI-12 commands that are often used in an SDI-12 system and the corresponding responses from METER sensors.

IDENTIFICATION COMMAND (aI!)

The Identification command can be used to obtain a variety of detailed information about the connected sensor. An example of the command and response is shown in [Example 1](#), where the command is in **bold** and the response follows the command.

Example 1 **1I!**113METER_ _ _ 5TM_ _ _ 329631800001

<u>Parameter</u>	<u>Fixed Character Length</u>	<u>Description</u>
1I!	3	Data logger command. Request to the sensor for information from sensor address 1.
1	1	Sensor address. Prepended on all responses, this indicates which sensor on the bus is returning the following information.
13	2	Indicates that the target sensor supports SDI-12 Specification v1.3 .
METER_ _ _	8	Vendor identification string. (METER and three spaces _ _ _ for all METER sensors)
5TM_ _ _	6	Sensor model string. This string is specific to the sensor type. For the 5TM, the string is 5TM.
329	3	Sensor version. This number divided by 329 is the METER sensor version (e.g., 329 is version 3.29).
631800001	≤13, variable	Sensor serial number. This is a variable length field. It may be omitted for older sensors.

NOTE: In the event that the fixed length is longer than the parameter, the trailing characters will be populated with space characters.

CHANGE ADDRESS COMMAND (aAB!)

The Change Address command is used to change the sensor address to a new address. All other commands support the wildcard character as the target sensor address except for this command. All METER sensors have a default address of 0 (zero) out of the factory. Supported addresses are alphanumeric (i.e., a–z, A–Z, and 0–9). An example output from a METER sensor is shown in [Example 2](#), where the command is in **bold** and the response follows the command.

Example 2 **1A0!**0

<u>Parameter</u>	<u>Fixed Character Length</u>	<u>Description</u>
1A0!	4	Data logger command. Request to the sensor to change its address from 1 to a new address of 0.
0	1	New sensor address. For all subsequent commands, this new address will be used by the target sensor.

ADDRESS QUERY COMMAND (?!)

While disconnected from a bus, the Address Query command can be used to determine which sensor is currently being communicated with. Sending this command over a bus will cause a bus contention where all the sensors will respond simultaneously and corrupt the data line. This command is helpful when trying to isolate a failed sensor. [Example 3](#) shows an example of the command and response, where the command is in **bold** and the response follows the command. The question mark (?) is a wildcard character that can be used in place of the address with any command except the Change Address command.

Example 3 ?!0

Parameter	Fixed Character Length	Description
?!	2	Data logger command. Request for a response from any sensor listening on the data line.
0	1	Sensor address. Returns the sensor address to the currently connected sensor.

COMMAND IMPLEMENTATION

The following tables list the relevant Measurement (M) and Data (D) commands when necessary.

MEASUREMENT COMMAND IMPLEMENTATION

Measurement (M) commands are sent to a single sensor on the SDI-12 bus and require that subsequent Data (D) commands are sent to that sensor to retrieve the sensor output data before initiating communication with another sensor on the bus.

Please refer to [Table 2](#) and for an explanation of the command sequence and see [Table 3](#) for an explanation of response parameters.

Table 2 aM! measurement command sequence

Command	Response
This command reports instantaneous values.	
aM!	atttn
aD0!	a+<dielectricPermittivity>+<electricalConductivity>±<temperature>

NOTES: The measurement and corresponding data commands are intended to be used back to back. After a measurement command is processed by the sensor, a service request a <CR><LF> is sent from the sensor signaling the measurement is ready. Either wait until *ttt* seconds have passed or wait until the service request is received before sending the data commands. See the [SDI-12 Specifications v1.3](#) document for more information.

The value of <electricalConductivity> will be 0.

PARAMETERS

[Table 3](#) lists the parameters, unit measurement, and a description of the parameters returned in command responses for 5TM.

Table 3 Parameter descriptions

Parameter	Unit	Description
±	—	Positive or negative sign denoting sign of the next value
a	—	SDI-12 address
n	—	Number of measurements (fixed width of 1)
nn	—	Number of measurements with leading zero if necessary (fixed width of 2)
ttt	s	Maximum time measurement will take (fixed width of 3)
<TAB>	—	Tab character
<CR>	—	Carriage return character
<LF>	—	Line feed character
<dielectricPermittivity>	ε	Dielectric permittivity (ε)
<temperature>	°C	Soil temperature
<rawDielectricPermittivity>	ε	Encoded dielectric permittivity
<rawTemperature>	°C	Encoded soil temperature

Table 3 Parameter descriptions (continued)

Parameter	Unit	Description
<sensorType>		ASCII character denoting the sensor type. For 5TE, the character is 2.
<checksum>		METER serial checksum

NOTE: The value of <electricalConductivity> will be 0.

DDI SERIAL COMMUNICATION

The DDI serial communications protocol is ideal for systems that have dedicated serial signaling lines for each sensor or use a multiplexer to handle multiple sensors. The serial communications are compatible with many TTL serial implementations that support active-high logic levels using 0.0 to 3.6 VDC signal levels. When the sensor is first powered, it automatically makes measurements of the integrated transducers then outputs a response over the data line. Systems using this protocol control the sensor excitation to initiate data transfers from the sensor. This protocol is subject to change as METER improves and expands the line of digital sensors and data loggers.

For 5TM sensors with firmware version 3.29 and newer, the startup string is omitted when the SDI-12 address is nonzero.

NOTE: Out of the factory, all METER sensors start with SDI-12 address 0 and print out the startup string when power cycled. On sensors with firmware version 3.29 and newer the startup string is omitted when the address is nonzero.

DDI SERIAL TIMING

Table 4 lists the DDI serial communication configuration.

Table 4 DDI serial communication configuration

Baud Rate	1200
Start Bits	1
Data Bits	8 (LSB first)
Parity Bits	0 (none)
Stop Bits	1
Logic	Standard (active high)

At power up, the sensor will pull the data line high within 100 ms to indicate that the sensor is taking a reading (Figure 6). When the reading is complete, the sensor begins sending the serial signal out the data line adhering to the format shown in Figure 7. Once the data is transmitted, the sensor goes into SDI-12 communication mode. To get another serial signal, the sensor must be power cycled.

NOTE: Sometimes the signaling from the sensor can confuse typical microprocessor UARTs. The sensor holds the data line low while taking measurements. The sensor raises the line high to signal the logger that it will send a measurement. Then the sensor may take some additional measurements before starting to clock out the first data byte starting with a typical start bit (low). Once the first start bit is sent, typical serial timing is valid; however, the signal transitions before this point are not serial signaling and may be misinterpreted by the UART.

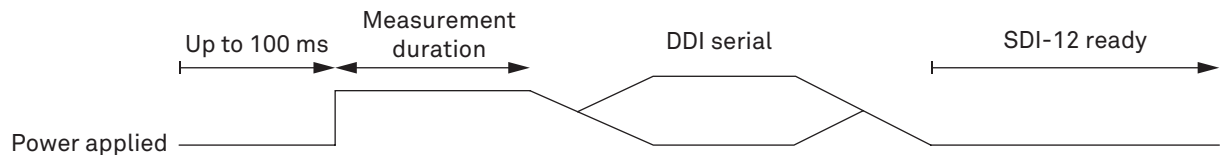

Figure 6 Data line DDI serial timing

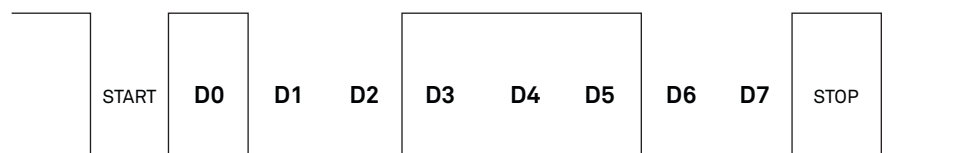

Figure 7 Example DDI serial transmission of the character 9 (0x39)

DDI SERIAL RESPONSE

Table 5 details the DDI serial response.

Table 5 DDI serial response

COMMAND	RESPONSE
NA	<TAB><rawDielectricPermittivity> <rawTemperature><CR><sensorType><checksum>

NOTES: There is no actual command. The response is returned automatically upon power up.

Raw dielectric output in the format raw output = dielectric × 50.

Raw temperature (T_{raw}).

$$T_{decompressed} = 5(T_{raw} - 900) + 900$$

where T is the degrees Celsius. To convert it to temperature, subtract 400 and divide by 10.

DDI SERIAL CHECKSUM

The legacy checksum is computed from the start of the transmission to the sensor identification character. The more robust CRC6 checksum, if available, is computed from the start of the transmission to the legacy checksum character.

Example input **56 0 645<CR>x** and the resulting CRC6 output = **_**.

```
char CalculateChecksum(char * response)
{
    int length, sum = 0, i, crc;

    // Finding the length of the response string
    length = strlen(response);

    // Adding characters in the response together
    for( i = 0; i < length; i++ )
        sum += response[i];

    // Converting checksum to a printable character
    crc = sum % 64 + 32;

    return crc;
}
```

CUSTOMER SUPPORT

NORTH AMERICA

Customer service representatives are available for questions, problems, or feedback Monday through Friday, 7:00 am to 5:00 pm Pacific time.

Email: support.environment@metergroup.com
sales.environment@metergroup.com

Phone: +1.509.332.5600

Fax: +1.509.332.5158

Website: metergroup.com

EUROPE

Customer service representatives are available for questions, problems, or feedback Monday through Friday, 8:00 to 17:00 Central European time.

Email: support@metergroup.de
sales@metergroup.de

Phone: +49 89 12 66 52 0

Fax: +49 89 12 66 52 20

Website: metergroup.de

If contacting METER by email, please include the following information:

Name	Email address
Address	Instrument serial number
Phone number	Description of problem

NOTE: For products purchased through a distributor, please contact the distributor directly for assistance.

REVISION HISTORY

The following table lists document revisions.

Revision	Date	Compatible Firmware	Description
01	3.29.2019	3.29	Changed DDI serial response example.
00	4.2.2018	3.29	Rebranded document for METER.